



ConnectCore 91

System-on-Module

Hardware Reference Manual

Revision history—90002600

Revision	Date	Description
1P	October 2024	Initial release.

Trademarks and copyright

Digi, Digi International, and the Digi logo are trademarks or registered trademarks in the United States and other countries worldwide. All other trademarks mentioned in this document are the property of their respective owners.

© 2024 Digi International Inc. All rights reserved.

Disclaimers

Information in this document is subject to change without notice and does not represent a commitment on the part of Digi International. Digi provides this document “as is,” without warranty of any kind, expressed or implied, including, but not limited to, the implied warranties of fitness or merchantability for a particular purpose. Digi may make improvements and/or changes in this manual or in the product(s) and/or the program(s) described in this manual at any time.

Warranty

To view product warranty information, go to the following website:

www.digi.com/howtobuy/terms

Customer support

Gather support information: Before contacting Digi technical support for help, gather the following information:

- Product name and model
- Product serial number (s)
- Firmware version
- Operating system/browser (if applicable)
- Logs (from time of reported issue)
- Trace (if possible)
- Description of issue
- Steps to reproduce

Contact Digi technical support: Digi offers multiple technical support plans and service packages. Contact us at +1 952.912.3444 or visit us at www.digi.com/support.

Feedback

To provide feedback on this document, email your comments to

techcomm@digicom.com

Include the document title and part number (ConnectCore 91 System-on-Module, 90002600 1P) in the subject line of your email.

Contents

About the ConnectCore 91 SOM

Features and functionality	5
Safety instructions	7
Block diagrams	7
ConnectCore 91 module	7
i.MX 91 application processor	7
Power interfaces	9
Reference power diagram	9
System-on-module power architecture	9
Electrical characteristics	11
Bootstrap	13
Wireless interfaces	15
WLAN IEEE 802.11a/b/g/n/ac/ax	15
RF channels	19
Transmit power	22
Antenna ports	23
Bluetooth	23

Module pinout

External signals and pin multiplexing	25
Castellated pad signals and multiplexing	27
LGA signals and multiplexing	41

Module specifications

Mechanical specifications	81
Host PCB footprint and cutout	81
Label	81
Weight	81
Environmental specifications	82

About the ConnectCore 91 SOM

The Digi ConnectCore® 91 System-on-Module (SOM) platform is a highly integrated, cost-effective, connected, secure embedded solution, built on the i.MX 91 MPU family. It integrates memory, power management, pre-certified wireless connectivity, and advanced Digi TrustFence device security with a complete, open-source Linux software platform based on the Yocto Project.

Features and functionality

The ConnectCore 91 system-on-module is based on the i.MX 91 processor from NXP. This processor offers a number of interfaces, most of them multiplexed and not available simultaneously. The module has the following features:

- Single Cortex-A55 processor:
 - Frequency operating at up to 1.4 GHz.
 - 32 KB L1 instruction cache.
 - 32 KB L1 data cache.
 - 256 KB L2 cache.
 - Media Processing Engine (MPE) with ARM NEON technology supporting the Advanced Single Instruction Multiple Data architecture.
 - Floating Point Unit (FPU) with support of the Arm VFPv4-D16 architecture.
 - Support of 64-bit Arm v8.2-A architecture.
 - Parity/ECC protection on L1 cache, L2 cache, and TLB RAMs.
 - Boot ROM (256 KB).
 - On-chip RAM (384 KB).
 - Security:
 - Trusted resource domain controller (TRDC).
 - ARM TrustZone (TZ) architecture, including Trustzone-A.
 - On-chip RAM (OCRAM) secure region protection using OCRAM controller.
 - EdgeLock secure enclave.
 - Battery backed security module (BBSM):
 - Secure non-volatile storage (SNVS).
 - Secure real-time clock (RTC).
- System debug:
 - Arm CoreSight debug and trace technology.
 - Embedded trace FIFO (ETF) with 4 KB internal storage to provide trace buffering.
 - Unified trace capability for single core Cortex-A55.
 - Cross Triggering Interface (CTI).
 - 4-pin JTAG.

- Image sensor interface (ISI):
 - Standard pixel formats commonly used in many camera input protocols.
 - Programmable resolutions up to 2K.
 - Image processing for:
 - Supports one source of up to 2K horizontal resolution.
 - Supports pixel rate up to 200 Mpixel/s.
 - Image down scaling via decimation and bi-phase filtering.
 - Color space conversion.
 - Interlaced to progressive conversions.
- Connectivity:
 - x2 USB 2.0 controllers and PHYs interfaces.
 - x1 CAN/CAN-FD.
 - x2 I3C.
 - x2 32-pin FlexIO modules.
 - x3 uSDHC.
 - x2 Ethernet controllers:
 - x1 Gigabit Ethernet controller with support for Energy Efficient Ethernet (EEE), Ethernet AVB and IEEE 1588.
 - x1 Gigabit Ethernet controller with support for TSN in addition to EEE, Ethernet AVB and IEEE 1588.
 - x8 LPSPI.
 - x8 I2C.
 - x8 LPUART.
- Multimedia:
 - LCDIF display controller
 - Parallel camera
 - Audio:
 - x3 SAI interfaces:
 - SAI1 supports 2 lanes TX and 1 lane RX
 - SAI2 supports 1 lane TX and 1 lane RX
 - SAI3 supports 1 lane TX and 1 lane RX
 - x1 SPDIF
 - 24-bit PDM supports up to 8-microphones (4 lanes)
- Up to 512 MB, 16-bit LPDDR4 memory.
- Up to 8 GB, 8-bit eMMC memory.
- NXP PCA9451 Power Management IC (PMIC):
 - x6 Step down regulators.
 - x5 Linear regulators.
 - x1 Load switch.
- IEEE 802.11 a/b/g/n/ac/ax WLAN interface.

- Bluetooth version 5.4.

Safety instructions

- The ConnectCore 91 SOM cannot be guaranteed operation due to the radio link and so should not be used for interlocks in safety critical devices such as machines or automotive applications.
- The ConnectCore 91 SOM has not been approved for use in (this list is not exhaustive):
 - nuclear applications
 - explosive or flammable atmospheres
- There are no user serviceable components inside the ConnectCore 91 SOM. Do not modify the ConnectCore 91 in any way. Modifications may exclude the SOM from any warranty and can cause the ConnectCore 91 to operate outside of regulatory compliance for a given country, leading to the possible illegal operation of the radio.
- Use industry standard ESD protection when handling the ConnectCore 91 SOM.
- Take care while handling to avoid electrical damage to the PCB and components.
- Do not expose ConnectCore 91 SOM to water or moisture.
- Use this product with the antennas specified in the ConnectCore 91 SOM user guides.
- The end user must be told how to remove power from the ConnectCore 91 SOM or to locate the antennas 20 cm from humans or animals.

Block diagrams

The figures below show block diagrams of the ConnectCore 91 module and of the NXP i.MX 91 application processor.

ConnectCore 91 module

The ConnectCore 91 module block diagram will be available in a future release of this manual.

i.MX 91 application processor

Note This is a preliminary diagram.

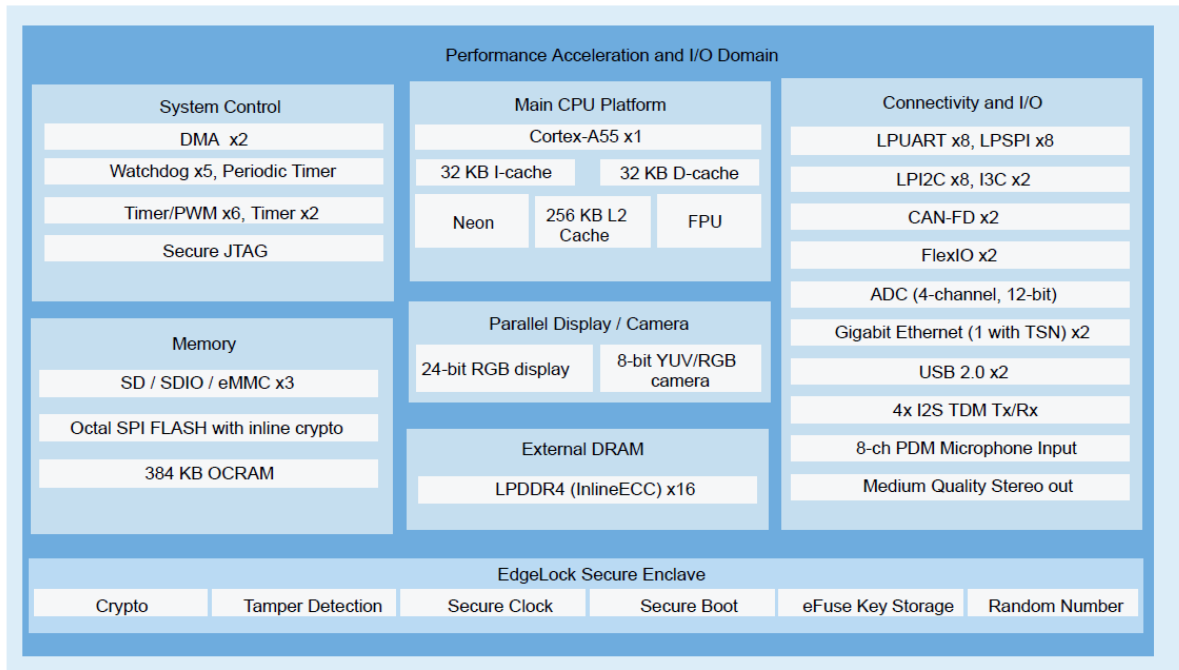

Power interfaces

Reference power diagram

The following diagram represents the power architecture of the ConnectCore 91 module in a typical application:

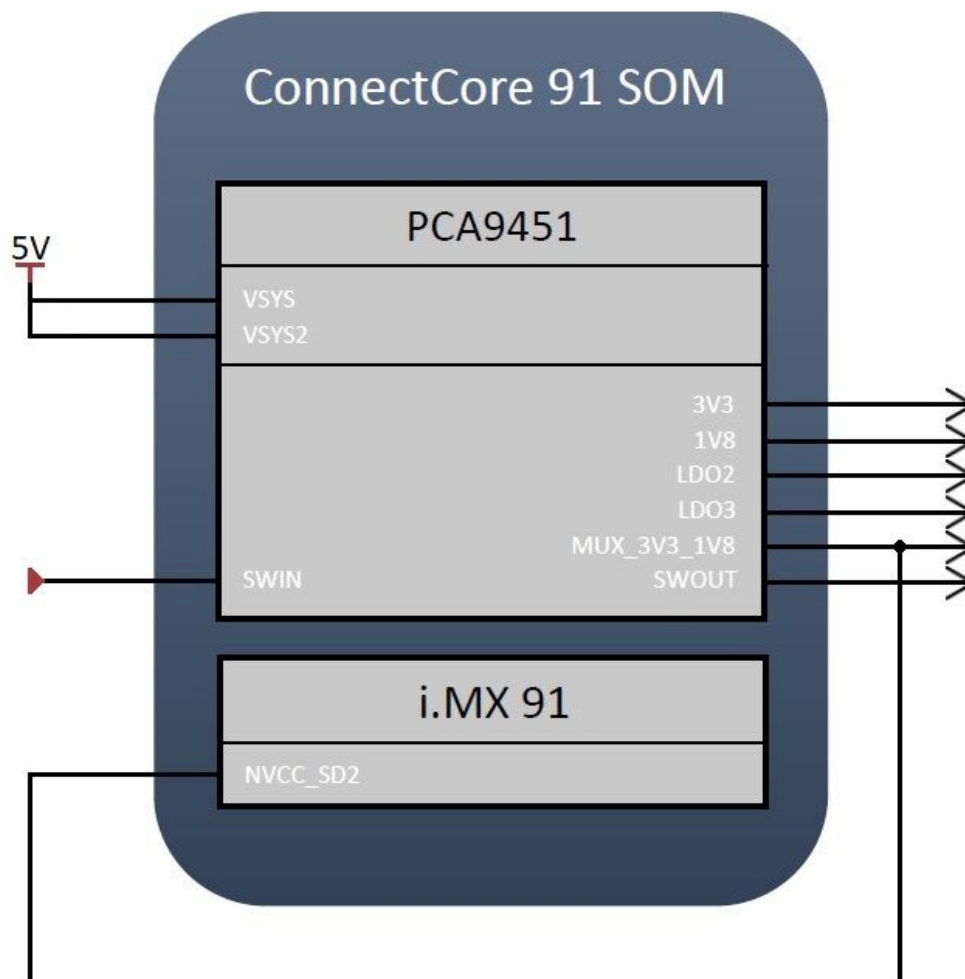

System-on-module power architecture

The ConnectCore 91 requires two primary power supply inputs: VSYS and VSYS2. These supplies are the input power supplies to the on-module NXP PCA9451 power management IC (PMIC), which generates all required supply voltages for the module as well as the external interfaces.

The following table summarizes the PMIC regulators and switches on the ConnectCore 91 SOM:

PMIC regulator	SOM power rail name	Input power supply	Internally used	Externally available
BUCK1	-	VSYS2	YES	NO
BUCK2	-	VSYS2	YES	NO
BUCK3	-	VSYS2	YES	NO
BUCK4	3V3	VSYS	YES	YES
BUCK5	1V8	VSYS2	YES	YES
BUCK6	-	VSYS2	YES	NO
LDO1	-	VSYS2	YES	NO
LDO4	-	VSYS2	YES	NO
LDO5	MUX_3V3_1V8	VSYS2	NO	YES
Load switch	SWOUT	SWIN	NO	YES

In addition to the input power supplies of the PMIC, other power domains of the SOM must also be set externally. This allows power management flexibility so you can adapt the input voltage of the different interfaces. The following table lists the input power rails that must be powered externally to the SOM together with the devices/power domains they power:

Input rail	Internally connected to	Description
NVCC_SD2	NVCC_SD2 pin of the i.MX 91 CPU	IO supply for uSDHC2

Electrical characteristics

Input power rails

The following table lists the electrical specifications of all input power rails for the ConnectCore 91:

Device	SOM power rail		Input voltage (V)		
			Minimum	Typical	Maximum
PMIC	VSY1		3.7	-	6.0 ¹
	VSY2		2.7	-	6.0 ¹
CPU	NVCC_SD2	1.8V mode	1.62	1.80	1.98
		3.3V mode	3.00	3.30	3.465

¹ Absolute maximum ratings.

Output power rails

The following table lists the electrical specifications of all output power rails for the ConnectCore 91:

SOM power rail	Used internally in the SOM	Output voltage			Accuracy (%)		Continuous output current (mA) ¹	Startup time (µs)	
		Min	Typ	Max	Min	Max		Typ	Max
3V3	YES	0.6	-	3.4	-2	2	3000	250	500
1V8	YES	0.6	-	3.4	-2	2	2000	250	500
MUX_3V3_1V8	NO	1.8	-	3.3	-3	3	150	200	-
SWOUT	NO	2.8	-	5.5	-	-	400	200	500

Note Some of the electrical characteristics may depend on the configuration and operation mode of the different regulators. For a complete description of the electrical characteristics of the different output power rails (PMIC regulators), see the PCA9451 datasheet.

¹ The maximum output current involves both external and internal circuitry. For those regulators that are used internally in the SOM, the current available outside will be lower.

Bootstrap

The ConnectCore 91 module can be configured to boot from different devices and interfaces. The boot mode can be selected in two ways:

- Through the boot mode pins (recommended for development).
- Overridden by fuses (recommended for production).

When using the boot mode pins, the boot mode is determined by the binary value stored in the internal BOOT_MODE register. The boot mode is initialized by sampling the BOOT_MODE[3:0] inputs on the rising edge of POR_B. After these inputs are sampled, the subsequent states do not affect BOOT_MODE internal register value.

The BOOT_MODE[3:0] bits are available in the following signals of the SOM:

Signal	Boot mode
BT_UART1_TX	BOOT0
BT_UART1_RTS	BOOT1
SPI1_CS0	BOOT2
SPI1_SCK	BOOT3

Note BT_UART1_RTS (BOOT1) has an internal pull-up to set the module to boot from the on-module eMMC by default.

The following table lists the different boot modes available on the ConnectCore 91 module:

BOOT core	BOOT_MODE[3:0]	Boot mode
Cortex-A55	0000	Internal fuses
	0001	Serial downloader
	0010	USDHC1 8-bit eMMC 5.1
	0011	USDHC2 47-bit SD3.0
	0100	FlexSPI serial NOR
	0101	FlexSPI serial NAND 2K page
	0110	Infinite loop
	0111	Test mode
Cortex-M33	1000	Internal fuses
	1001	Serial downloader
	1010	USDHC1 8-bit eMMC 5.1
	1011	USDHC2 47-bit SD3.0
	1100	FlexSPI serial NOR
	1101	FlexSPI serial NAND 2K page
	1110	Infinite loop
	1111	Test mode

Wireless interfaces

The ConnectCore 91 System-on-module combines a wireless local area network (WLAN) and Bluetooth dual solution to support IEEE802.11 a/b/g/n/ac/ax WLAN standards and Bluetooth 5.4, enabling seamless integration of WLAN/Bluetooth and Low Energy technology. Digi also offers a non-wireless variant of the ConnectCore 91 module.

The following sections include specifications for the wireless interfaces available on the ConnectCore 91 module.

WLAN IEEE 802.11a/b/g/n/ac/ax

The following sections specify the performance of the WLAN IEEE 802.11a/b/g/n/ac/ax interface on the ConnectCore 91 module.

Modulation and data rates

The following tables list modulation values for the ConnectCore 91 module, which supports the following WLAN standards:

Mode	Modulation & coding	Rate
802.11b	DBPSK	1 Mbps
	DQPSK	2 Mbps
	CCK	5.5 Mbps
	CCK	11 Mbps

Mode	Modulation & coding	Rate
802.11ga	BPSK-1/2	6 Mbps
	BPSK-3/4	9 Mbps
	QPSK-1/2	12 Mbps
	QPSK-3/4	18 Mbps
	16QAM-1/2	24 Mbps
	16QAM-3/4	36 Mbps
	64QAM-2/3	48 Mbps
	64QAM-3/4	54 Mbps
802.11n	BPSK-1/2	MCS0
	QPSK-1/2	MCS1
	QPSK-3/4	MCS2
	16QAM-1/2	MCS3
	16QAM-3/4	MCS4
	64QAM-2/3	MCS5
	64QAM-3/4	MCS6
	64QAM-5/6	MCS7

Mode	Modulation & coding	Rate
802.11ac	BPSK-1/2	MCS0
	QPSK-1/2	MCS1
	QPSK-3/4	MCS2
	16QAM-1/2	MCS3
	16QAM-3/4	MCS4
	64QAM-2/3	MCS5
	64QAM-3/4	MCS6
	64QAM-5/6	MCS7
	256QAM-3/4	MCS8
	256QAM-5/6	MCS9
802.11ax	BPSK-1/2	MCS0
	QPSK-1/2	MCS1
	QPSK-3/4	MCS2
	16QAM-1/2	MCS3
	16QAM-3/4	MCS4
	64QAM-2/3	MCS5
	64QAM-3/4	MCS6
	64QAM-5/6	MCS7
	256QAM-3/4	MCS8
	256QAM-5/6	MCS9
	1024QAM-3/4	MCS10
	1024QAM-5/6	MCS11

Data rate (Mbps) - Non Short Guard Interval (Non-SGI)

Data rate (Mbps)		802.11b		802.11ga		802.11n		802.11ac			802.11ax		
		DBPSK	CCK	BPSK-1/2	64QAM-3/4	BPSK-1/2	64QAM-5/6	BPSK-1/2	64QAM-5/6	256QAM-5/6	BPSK-1/2	64QAM-5/6	1024QAM-5/6
Modulation		1 Mbps	11 Mbps	6 Mbps	54 Mbps	MCS0	MCS7	MCS0	MCS7	MCS9	MCS0	MCS7	MCS11
2.4 GHz	HT20	1	11	6	54	6.5	65	6.5	65		4	81	135
	HT40					13.5	135	13.5	135	180	8	163	271
5 GHz	HT20			6	54	6.5	65	6.5	65		4	81	135
	HT40					13.5	135	13.5	135	180	8	163	271
	HT80							29.3	292.5	390	17	340	600

Data rate (Mbps) - Short Guard Interval (SGI)

Mode		802.11b		802.11ga		802.11n		802.11ac			802.11ax		
		DBPSK	CCK	BPSK-1/2	64QAM-3/4	BPSK-1/2	64QAM-5/6	BPSK-1/2	64QAM-5/6	256QAM-5/6	BPSK-1/2	64QAM-5/6	1024QAM-5/6
Modulation		1 Mbps	11 Mbps	6 Mbps	54 Mbps	MCS0	MCS7	MCS0	MCS7	MCS9	MCS0	MCS7	MCS11
2.4 GHz	HT20	1	11	6	54	7.2	72.2	7.2	72.2		8.6	86	143
	HT40					15	150	15	150	200	17.2	172	287
5 GHz	HT20			6	54	7.2	72.2	7.2	72.2		8.6	86	143
	HT40					15	150	15	150	200	17.2	172	287
	HT80							32.5	325	433.3	36	360	600

RF channels

The ConnectCore 91 module supports the following frequency bands:

RF band	Ch. BW	Ch. spacing	Channel number (Center freq. MHz)
2.4 GHz	20 MHz	5 MHz	1(2412), 2(2417), 3(2422), 4(2427), 5(2432), 6(2437), 7(2442), 8(2447), 9(2452), 10(2457), 11(2462), 12(2467), 13(2472), 14(2484)
	40 MHz	5 MHz	3(2422), 11(2462)
5 GHz	20 MHz	20 MHz	36(5180), 40(5200), 44(5220), 48(5240), 52(5260), 56(5280), 60(5300), 64(5320), 100(5500), 104(5520), 108(5540), 112(5560), 116(5580), 120(5600), 124(5620), 128(5640), 132(5660), 136(5680), 140(5700), 144(5720), 149(5745), 153(5765), 157(5785), 161(5805), 165(5825)
	40 MHz	40 MHz	38(5190), 46(5230), 54(5270), 62(5310), 102(5510), 110(5550), 118(5590), 126(5630), 134(5670), 142(5710), 151(5755), 159(5795)
	80 MHz	80 MHz	42(5210), 58(5290), 106(5530), 122(5610), 138(5690), 155(5775)

Note Dependent upon regulatory bodies.

2.4 GHz

2.4 GHz band channel #	Center frequency (MHz)	EUROPE (ETSI)	NORTH AMERICA (FCC)	JAPAN
1	2412	✓	✓	✓
2	2417	✓	✓	✓
3	2422	✓	✓	✓

2.4 GHz band channel #	Center frequency (MHz)	EUROPE (ETSI)	NORTH AMERICA (FCC)	JAPAN
4	2427	✓	✓	✓
5	2432	✓	✓	✓
6	2437	✓	✓	✓
7	2442	✓	✓	✓
8	2447	✓	✓	✓
9	2452	✓	✓	✓
10	2457	✓	✓	✓
11	2462	✓	✓	✓
12	2467	✓	No	✓
13	2472	✓	No	✓
14	2484	No	No	802.11b only

5 GHz

5 GHz band channel #	Center frequency (MHz)	EUROPE (ETSI)	NORTH AMERICA (FCC)	JAPAN
36	5180	Indoors	✓	✓
40	5200	Indoors	✓	✓
44	5220	Indoors	✓	✓
48	5240	Indoors	✓	✓
52	5260	Indoors / DFS / TPC	DFS	DFS / TPC
56	5280	Indoors / DFS / TPC	DFS	DFS / TPC

5 GHz band channel #	Center frequency (MHz)	EUROPE (ETSI)	NORTH AMERICA (FCC)	JAPAN
60	5300	Indoors / DFS / TPC	DFS	DFS / TPC
64	5320	Indoors / DFS / TPC	DFS	DFS / TPC
100	5500	DFS / TPC	DFS	DFS / TPC
104	5520	DFS / TPC	DFS	DFS / TPC
108	5540	DFS / TPC	DFS	DFS / TPC
112	5560	DFS / TPC	DFS	DFS / TPC
116	5580	DFS / TPC	DFS	DFS / TPC
120	5600	DFS / TPC	DFS	DFS / TPC
124	5620	DFS / TPC	DFS	DFS / TPC
128	5640	DFS / TPC	DFS	DFS / TPC
132	5660	DFS / TPC	DFS	DFS / TPC
136	5680	DFS / TPC	DFS	DFS / TPC
140	5700	DFS / TPC	DFS	DFS / TPC
149	5745	SRD	✓	No Access
153	5765	SRD	✓	No Access
157	5785	SRD	✓	No Access
161	5805	SRD	✓	No Access
165	5825	SRD	✓	No Access

Note

DFS = Dynamic Frequency Selection

TPC = Transmit Power Control

SRD = Short Range Devices 25 mW max power

Transmit power

The following table lists nominal transmit power values for the ConnectCore 91 module based on NXP IW612 and Murata LBES5PL2EL specifications.

RF band (GHz)	Bandwidth (MHz)	Condition	Output power (dBm)
2.4	20	802.11b	21
		MCS7	20
		MCS8	19
		MCS11	18
	40	MCS7	20
		MCS9	19
MCS11		18	
5	20	MCS7	19.5
		MCS8	18
		MCS11	15.5
	40	MCS7	19
		MCS9	17
		MCS11	15.5
	80	MCS7	18
		MCS9	16.5
		MCS11	13.5

Note Output power values are subject to change.

Antenna ports

The ConnectCore 91 module has one antenna port on the module via a dedicated U.FL connector. The antenna port supports WLAN and Bluetooth functionality.

Bluetooth

The ConnectCore 91 module supports both Bluetooth and Bluetooth Low Energy protocols:

- Bluetooth 5.4 with backward-compatibility. Bluetooth class 1 and class 2 transmitter operation.
- Integrated WLAN-Bluetooth coexistence.

Module pinout

The ConnectCore 91 module has a mixed pad structure. The module provides 474 LGA pins, 118 of them connected to the peripheral castellated pads. The general layout can be found on the following diagram:

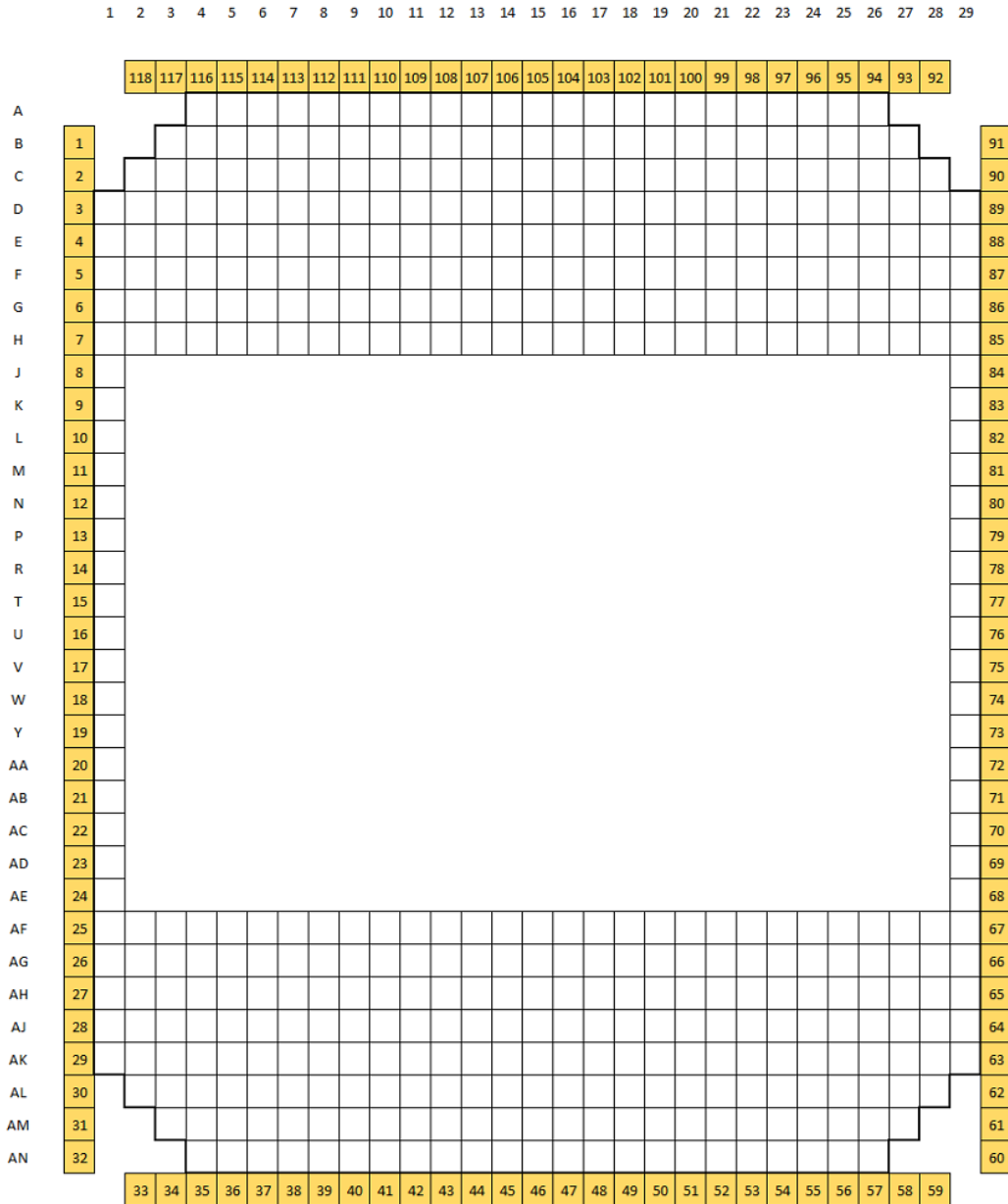

White cells: LGA pads
Orange cells: castellated pads

Note The diagram represents the module as seen from the top side with antenna on top-right corner.

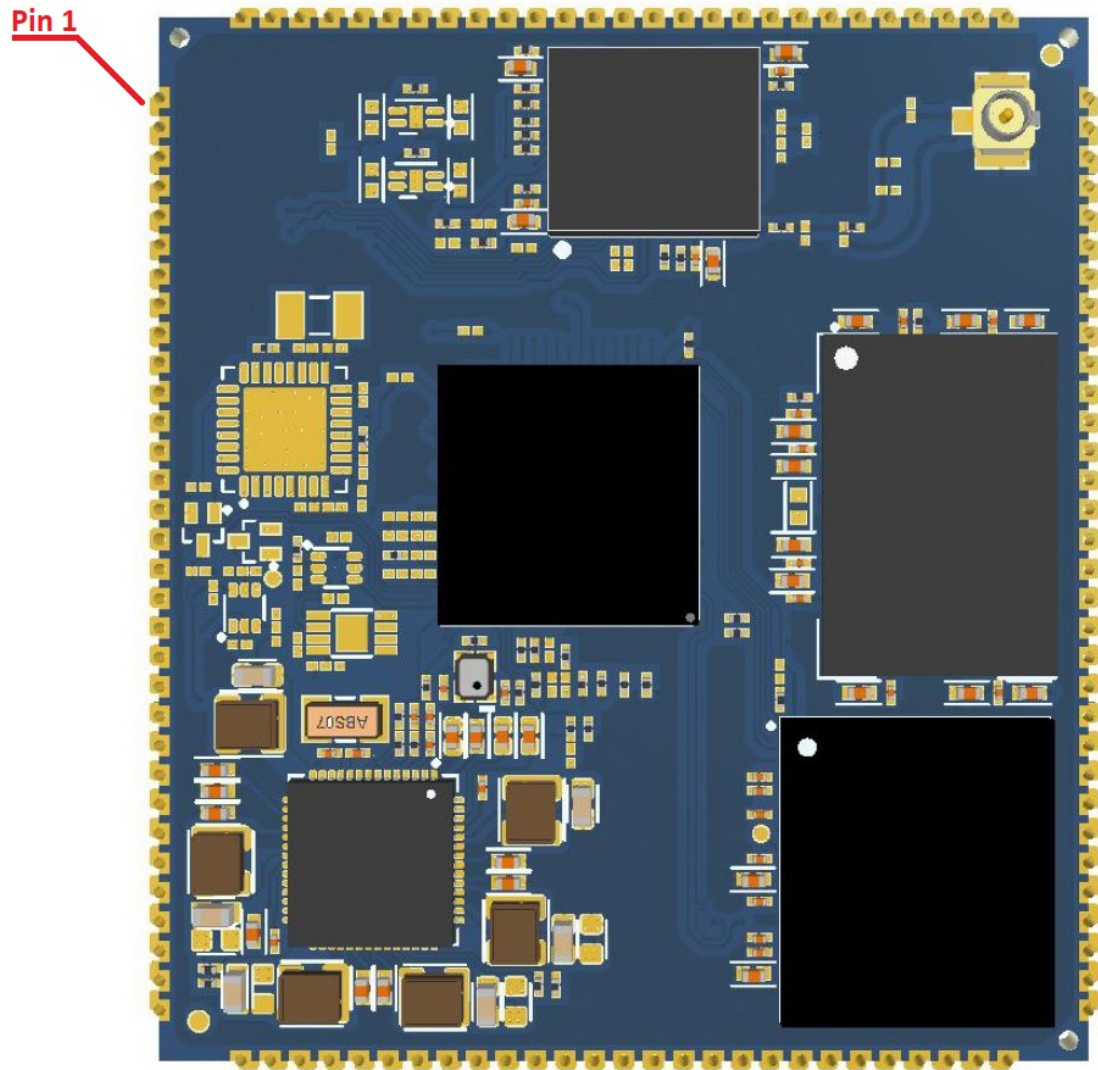

External signals and pin multiplexing

The following tables provide the pinout information of the ConnectCore 91 module. For additional information related to the signals listed in the table, refer to the NXP i.MX 91 technical documentation.

Note The Digi ConnectCore Smart IOMUX tool can dramatically simplify pin configuration and resolution. You can enter the list of interfaces required by your project and use the Smart IOMUX graphical interface to mock up configuration options, resulting in full pin assignment and device tree snippets that match your desired functionality. See the [Smart IOMUX User Guide](#) for more information and download instructions.

The microprocessor used on this module, like all CMOS devices, can be driven into a latch-up condition if any I/O pin is driven outside of its associated power rail. Care must be taken to:

- Never drive an I/O pin beyond its positive rail or below ground.
- Never drive an I/O pin from an external power source during the power-on or reset sequences.
- Never hot-swap the module or interrupt its ground connection to external circuitry.



Latch-up is a condition that can cause excessive current draw and result in excessive heating of the microprocessor or its power supplies. This excessive heating can permanently damage the microprocessor and/or its supporting components.

When you use an external supply on the carrier board supporting the ConnectCore 91 module, make sure this supply is NOT back driving i.MX 91 I/Os while their power rails are not enabled. For example, this can happen when an external 3.3V supply is available on the carrier board and this supply powers components driven by i.MX 91 I/Os. In this case, Digi recommends you enable the external power supply after internal 3.3V is enabled, or add the necessary protection circuitry to avoid back voltage (leakage).

Castellated pad signals and multiplexing

Castellated pad number	Associated LGA pad name	ConnectCore 91 signal name	i.MX 91 pin name	Multiplexing <i>(green value represents default functionality)</i>	Power group	Comments
1	E4	SD2_RESET_B	SD2_RESET_B	ALT0: USDHC2_RESET_B ALT1: LPTMR2_ALT2 ALT4: FLEXIO1_FLEXIO07 ALT5: GPIO3_IO07 ALT6: CCMSRCGPCMIX_SYSTEM_RESET	NVCC_SD2	
2	E3	GPIO2_IO19	GPIO_IO19	ALT0: GPIO2_IO19 ALT1: SAI3_RX_SYNC ALT2: PDM_BIT_STREAM03 ALT3: MEDIAMIX_DISP_DATA15 ALT4: LPSPI5_SIN ALT5: LPSPI4_SIN ALT6: TPM6_CH2 ALT7: SAI3_TX_DATA00	3V3	
3	F3	NC	-	-	-	
4	G2	SD2_CD_B	SD2_CD_B	ALT0: USDHC2_CD_B ALT1: ENET_QOS_1588_EVENT0_IN ALT2: I3C2_SCL ALT3: LPI2C1_SCL ALT4: FLEXIO1_FLEXIO00 ALT5: GPIO3_IO00	NVCC_SD2	
5	F1	SD2_CMD	SD2_CMD	ALT0: USDHC2_CMD ALT1: ENET1_1588_EVENT0_IN ALT2: I3C2_PUR ALT3: I3C2_PUR_B ALT4: FLEXIO1_FLEXIO02 ALT5: GPIO3_IO02	NVCC_SD2	

Castellated pad number	Associated LGA pad name	ConnectCore 91 signal name	i.MX 91 pin name	Multiplexing (green value represents default functionality)	Power group	Comments
6	G1	SD2_DATA0	SD2_DATA0	ALT0: USDHC2_DATA0 ALT1: ENET2_1588_EVENT0_OUT ALT2: CAN2_TX ALT3: LPUART1_TX ALT4: FLEXIO1_FLEXIO03 ALT5: GPIO3_IO03	NVCC_ SD2	
7	H1	SD2_DATA1	SD2_DATA1	ALT0: USDHC2_DATA1 ALT1: ENET2_1588_EVENT1_IN ALT2: CAN2_RX ALT3: LPUART1_RX ALT4: FLEXIO1_FLEXIO04 ALT5: GPIO3_IO04	NVCC_ SD2	
8	J1	SD2_DATA2	SD2_DATA2	ALT0: USDHC2_DATA2 ALT1: ENET2_1588_EVENT1_OUT ALT2: MQS2_RIGHT ALT3: LPUART2_TX ALT4: FLEXIO1_FLEXIO05 ALT5: GPIO3_IO05	NVCC_ SD2	
9	K1	SD2_DATA3	SD2_DATA3	ALT0: USDHC2_DATA3 ALT1: LPTMR2_ALT1 ALT2: MQS2_LEFT ALT3: LPUART2_RX ALT4: FLEXIO1_FLEXIO06 ALT5: GPIO3_IO06	NVCC_ SD2	
10	L1	SD2_CLK	SD2_CLK	ALT0: USDHC2_CLK ALT1: ENET_QOS_1588_EVENT0_OUT ALT2: I3C2_SDA ALT3: I2C1_SDA ALT4: FLEXIO1_FLEXIO01 ALT5: GPIO3_IO01	NVCC_ SD2	

Castellated pad number	Associated LGA pad name	ConnectCore 91 signal name	i.MX 91 pin name	Multiplexing (green value represents default functionality)	Power group	Comments
11	M1	GND				
12	N1	NVCC_SD2				
13	P1	UART7_TX	GPIO_IO08	ALT0: GPIO2_IO08 ALT1: LPSPI3_PCS0 ALT2: MEDIAMIX_CAM_DATA02 ALT3: MEDIAMIX_DISP_DATA04 ALT4: TPM6_CH0 ALT5: LPUART7_TX ALT6: LPI2C7_SDA ALT7: FLEXIO1_FLEXIO08	3V3	
14	R1	UART7_RX	GPIO_IO09	ALT0: GPIO2_IO09 ALT1: LPSPI3_SIN ALT2: MEDIAMIX_CAM_DATA03 ALT3: MEDIAMIX_DISP_DATA05 ALT4: TPM3_EXTCLK ALT5: LPUART7_RX ALT6: LPI2C7_SCL ALT7: FLEXIO1_FLEXIO09	3V3	
15	T1	GND				
16	U1	NC	-	-	-	
17	V1	I2C2_SCL	I2C2_SCL	ALT0: LPI2C2_SCL ALT1: I3C1_PUR ALT2: LPUART2_DCB_B ALT3: TPM2_CH2 ALT4: SAI1_RX_SYNC ALT5: GPIO1_IO02 ALT6: I3C1_PUR_B	3V3	
18	W1	I2C2_SDA	I2C2_SDA	ALT0: LPI2C2_SDA ALT2: LPUART2_RIN_B	3V3	

Castellated pad number	Associated LGA pad name	ConnectCore 91 signal name	i.MX 91 pin name	Multiplexing (green value represents default functionality)	Power group	Comments
				ALT3: TPM2_CH3 ALT4: SAI1_RX_BCLK ALT5: GPIO1_IO03		
19	Y1	PDM_BIT_STREAM1	PDM_BIT_STREAM1	ALT0: PDM_BIT_STREAM01 ALT2: LPSPI2_PCS1 ALT3: TPM2_EXTCLK ALT4: LPTMR1_ALT3 ALT5: GPIO1_IO10	3V3	
20	AA1	GPIO2_IO06	GPIO_IO06	ALT0: GPIO2_IO06 ALT1: TPM5_CH0 ALT2: PDM_BIT_STREAM01 ALT3: MEDIAMIX_DISP_DATA02 ALT4: LPSPI7_SOUT ALT5: LPUART6_CTS_B ALT6: LPI2C7_SDA ALT7: FLEXIO1_FLEXIO06	3V3	
21	AB1	NC	-	-	-	
22	AC1	NC	-	-	-	
23	AD1	NC	-	-	-	
24	AE1	NC	-	-	-	
25	AF1	GPIO4_IO14 (1V8)	ENET2_MDC	ALT0: ENET2_MDC ALT1: LPUART4_DCB_B ALT2: SAI2_RX_SYNC ALT4: FLEXIO2_FLEXIO14 ALT5: GPIO4_IO14 ALT6: MEDIAMIX_CAM_CLK	1V8	
26	AG1	GPIO4_IO15 (1V8)	ENET2_MDIO	ALT0: ENET2_MDIO ALT1: LPUART4_RIN_B	1V8	

Castellated pad number	Associated LGA pad name	ConnectCore 91 signal name	i.MX 91 pin name	Multiplexing (green value represents default functionality)	Power group	Comments
				ALT2: SAI2_RX_BCLK ALT4: FLEXIO2_FLEXIO15 ALT5: GPIO4_IO15 ALT6: MEDIAMIX_CAM_DATA00		
27	AH1	1V8				
28	AJ1	GND				
29	AK1	3V3				
30	-	GND				
31	-	VSYS2				
32	-	VSYS2				
33	-	VSYS				
34	-	GND				
35	AN4	GPIO2_IO18	GPIO_IO18	ALT0: GPIO2_IO18 ALT1: SAI3_RX_BCLK ALT2: MEDIAMIX_CAM_DATA09 ALT3: MEDIAMIX_DISP_DATA14 ALT4: LPSPI5_PCS0 ALT5: LPSPI4_PCS0 ALT6: TPM5_CH2 ALT7: FLEXIO1_FLEXIO18	3V3	
36	AN5	SD2_VSELECT	SD2_VSELECT	ALT0: USDHC2_VSELECT ALT1: USDHC3_WP ALT2: LPTMR2_ALT3 ALT4: FLEXIO1_FLEXIO19 ALT5: GPIO3_IO19	1V8	
37	AN6	NC	-	-	-	

Castellated pad number	Associated LGA pad name	ConnectCore 91 signal name	i.MX 91 pin name	Multiplexing (green value represents default functionality)	Power group	Comments
38	AN7	NC	-	-	-	
39	AN8	GND				
40	AN9	NC	-	-	-	
41	AN10	NC	-	-	-	
42	AN11	GND				
43	AN12	NC	-	-	-	
44	AN13	NC	-	-	-	
45	AN14	GND				
46	AN15	NC	-	-	-	
47	AN16	NC	-	-	-	
48	AN17	GND				
49	AN18	NC	-	-	-	
50	AN19	NC	-	-	-	
51	AN20	GND				
52	AN21	NC	-	-	-	
53	AN22	NC	-	-	-	
54	AN23	NC	-	-	-	
55	AN24	NC	-	-	-	
56	AN25	SYS_RESET			Internal 1.8 V supply	Reset line of the module (active low).

Castellated pad number	Associated LGA pad name	ConnectCore 91 signal name	i.MX 91 pin name	Multiplexing (green value represents default functionality)	Power group	Comments
57	AN26	NC	-	-	-	
58	AM27	NC	-	-	-	
59	-	NC	-	-	-	
60	-	GND				
61	AL27	NC	-	-	-	
62	AL28	NC	-	-	-	
63	AK29	NC	-	-	-	
64	AJ29	NC	-	-	-	
65	AH29	NC	-	-	-	
66	AG29	NC	-	-	-	
67	AF29	NC	-	-	-	
68	AE29	NC	-	-	-	
69	AD29	NC	-	-	-	
70	AC29	NC	-	-	-	
71	AB29	NC	-	-	-	
72	AA29	NC	-	-	-	
73	Y29	GND				
74	W29	UART6_TX	GPIO_IO04	ALT0: GPIO2_IO04 ALT1: TPM3_CH0 ALT2: PDM_CLK ALT3: MEDIAMIX_DISP_DATA00 ALT4: LPSPI7_PCS0	3V3	

Castellated pad number	Associated LGA pad name	ConnectCore 91 signal name	i.MX 91 pin name	Multiplexing (green value represents default functionality)	Power group	Comments
				ALT5: LPUART6_TX ALT6: LPI2C6_SDA ALT7: FLEXIO1_FLEXIO04		
75	V29	UART6_RX	GPIO_IO05	ALT0: GPIO2_IO05 ALT1: TPM4_CH0 ALT2: PDM_BIT_STREAM00 ALT3: MEDIAMIX_DISP_DATA01 ALT4: LPSPI7_SIN ALT5: LPUART6_RX ALT6: LPI2C6_SCL ALT7: FLEXIO1_FLEXIO05	3V3	
76	U29	CAN1_RX	PDM_BIT_STREAM0	ALT0: PDM_BIT_STREAM00 ALT1: MQS1_RIGHT ALT2: LPSPI1_PCS1 ALT3: TPM1_EXTCLK ALT4: LPTMR1_ALT2 ALT5: GPIO1_IO09 ALT6: CAN1_RX	3V3	
77	T29	CAN1_TX	PDM_CLK	ALT0: PDM_CLK ALT1: MQS1_LEFT ALT4: LPTMR1_ALT1 ALT5: GPIO1_IO08 ALT6: CAN1_TX	3V3	
78	R29	CAN2_RX	GPIO_IO27	ALT0: GPIO2_IO27 ALT1: USDHC3_DATA3 ALT2: CAN2_RX ALT3: MEDIAMIX_DISP_DATA23 ALT4: TPM6_CH3 ALT5: JTAG_MUX_TMS ALT6: LPSPI5_PCS1 ALT7: FLEXIO1_FLEXIO27	3V3	

Castellated pad number	Associated LGA pad name	ConnectCore 91 signal name	i.MX 91 pin name	Multiplexing (green value represents default functionality)	Power group	Comments
79	P29	CAN2_TX	GPIO_IO25	ALT0: GPIO2_IO25 ALT1: USDHC3_DATA1 ALT2: CAN2_TX ALT3: MEDIAMIX_DISP_DATA21 ALT4: TPM4_CH3 ALT5: JTAG_MUX_TCK ALT6: LPSPI7_PCS1 ALT7: FLEXIO1_FLEXIO25	3V3	
80	N29	UART7_RTS	GPIO_IO11	ALT0: GPIO2_IO11 ALT1: LPSPI3_SCK ALT2: MEDIAMIX_CAM_DATA05 ALT3: MEDIAMIX_DISP_DATA07 ALT4: TPM5_EXTCLK ALT5: LPUART7_RTS_B ALT6: LPI2C8_SCL ALT7: FLEXIO1_FLEXIO11	3V3	
81	M29	UART7_CTS	GPIO_IO10	ALT0: GPIO2_IO10 ALT1: LPSPI3_SOUT ALT2: MEDIAMIX_CAM_DATA04 ALT3: MEDIAMIX_DISP_DATA06 ALT4: TPM4_EXTCLK ALT5: LPUART7_CTS_B ALT6: LPI2C8_SDA ALT7: FLEXIO1_FLEXIO10	3V3	
82	L29	ADC_IN1 (1V8)	ADC_IN1			
83	K29	ADC_IN0 (1V8)	ADC_IN0			
84	J29	NC	-	-	-	
85	H29	GND				
86	G29	TAMPER0 (1V8)	TAMPER0		Internal	

Castellated pad number	Associated LGA pad name	ConnectCore 91 signal name	i.MX 91 pin name	Multiplexing (green value represents default functionality)	Power group	Comments
					1.8V supply	
87	F29	TAMPER1 (1V8)	TAMPER1		Internal 1.8V supply	
88	E29	I2C4_SDA	GPIO_IO02	ALT0: GPIO2_IO02 ALT1: LPI2C4_SDA ALT2: MEDIAMIX_CAM_VSYNC ALT3: MEDIAMIX_DISP_VSYNC ALT4: LPSPI6_SOUT ALT5: LPUART5_CTS_B ALT6: LPI2C6_SDA ALT7: FLEXIO1_FLEXIO02	3V3	
89	F28	I2C4_SCL	GPIO_IO03	ALT0: GPIO2_IO03 ALT1: LPI2C4_SCL ALT2: MEDIAMIX_CAM_HSYNC ALT3: MEDIAMIX_DISP_HSYNC ALT4: LPSPI6_SCK ALT5: LPUART5_RTS_B ALT6: LPI2C6_SCL ALT7: FLEXIO1_FLEXIO03	3V3	
90	E28	GPIO2_IO22	GPIO_IO22	ALT0: GPIO2_IO22 ALT1: USDHC3_CLK ALT2: SPDIF_IN ALT3: MEDIAMIX_DISP_DATA18 ALT4: TPM5_CH1 ALT5: TPM6_EXTCLK ALT6: LPI2C5_SDA ALT7: FLEXIO1_FLEXIO22	3V3	
91	E27	GPIO2_IO23	GPIO_IO23	ALT0: GPIO2_IO23 ALT1: USDHC3_CMD ALT2: SPDIF_OUT ALT3: MEDIAMIX_DISP_DATA19	3V3	

Castellated pad number	Associated LGA pad name	ConnectCore 91 signal name	i.MX 91 pin name	Multiplexing (green value represents default functionality)	Power group	Comments
				ALT4: TPM6_CH1 ALT6: LPI2C5_SCL ALT7: FLEXIO1_FLEXIO23		
92	C24	GPIO2_IO24	GPIO_IO24	ALT0: GPIO2_IO24 ALT1: USDHC3_DATA0 ALT3: MEDIAMIX_DISP_DATA20 ALT4: TPM3_CH3 ALT5: JTAG_MUX_TDO ALT6: LPSPI6_PCS1 ALT7: FLEXIO1_FLEXIO24	3V3	
93	B24	SAI3_MCLK	GPIO_IO17	ALT0: GPIO2_IO17 ALT1: SAI3_MCLK ALT2: MEDIAMIX_CAM_DATA08 ALT3: MEDIAMIX_DISP_DATA13 ALT4: LPUART3_RTS_B ALT5: LPSPI4_PCS1 ALT6: LPUART4_RTS_B ALT7: FLEXIO1_FLEXIO17	3V3	
94	-	GND				
95	-	NC	-	-	-	
96	A24	ENET1_TXC	ENET1_TXC	ALT0: ENET_CCM_QOS_CLOCK_GENERATE_TX_CLK ALT1: ENET_QOS_TX_ER ALT2: LPSPI2_SIN ALT4: FLEXIO2_FLEXIO07 ALT5: GPIO4_IO07	1V8	
97	A23	ENET1_TX_CTL	ENET1_TX_CTL	ALT0: ENET_QOS_RGMII_TX_CTL ALT1: LPUART3_DTR_B ALT2: LPSPI2_SCK ALT4: FLEXIO2_FLEXIO06	1V8	

Castellated pad number	Associated LGA pad name	ConnectCore 91 signal name	i.MX 91 pin name	Multiplexing (green value represents default functionality)	Power group	Comments
				ALT5: GPIO4_IO06		
98	A22	ENET1_TXD0	ENET1_TD0	ALT0: ENET_QOS_RGMII_TD0 ALT1: LPUART3_TX ALT4: FLEXIO2_FLEXIO05 ALT5: GPIO4_IO05	1V8	
99	A21	ENET1_TXD1	ENET1_TD1	ALT0: ENET_QOS_RGMII_TD1 ALT1: LPUART3_RTS_B ALT2: I3C2_PUR ALT3: HSIOMIX_OTG_OC1 ALT4: FLEXIO2_FLEXIO04 ALT5: GPIO4_IO04 ALT6: I3C2_PUR_B	1V8	
100	A20	ENET1_TXD2	ENET1_TD2	ALT0: ENET_QOS_RGMII_TD2 ALT1: ENET_QOS_CLOCK_GENERATE_REF_CLK ALT2: CAN2_RX ALT3: HSIOMIX_OTG_OC2 ALT4: FLEXIO2_FLEXIO03 ALT5: GPIO4_IO03 ALT6: LPI2C2_SDA	1V8	
101	A19	ENET1_TXD3	ENET1_TD3	ALT0: ENET_QOS_RGMII_TD3 ALT2: CAN2_TX ALT3: HSIOMIX_OTG_ID2 ALT4: FLEXIO2_FLEXIO02 ALT5: GPIO4_IO02 ALT6: LPI2C2_SCL	1V8	
102	A18	ENET1_RXC	ENET1_RXC	ALT0: ENET_QOS_RGMII_RXC ALT1: ENET_QOS_RX_ER ALT2: LPSPi2_SOUT ALT4: FLEXIO2_FLEXIO09 ALT5: GPIO4_IO09	1V8	

Castellated pad number	Associated LGA pad name	ConnectCore 91 signal name	i.MX 91 pin name	Multiplexing (green value represents default functionality)	Power group	Comments
103	A17	ENET1_RX_CTL	ENET1_RX_CTL	ALT0: CCM_ENET_QOS_RGMII_RX_CTL ALT1: LPUART3_DSR_B ALT2: LPSPI2_PCS0 ALT3: HSIOMIX_OTG_PWR2 ALT4: FLEXIO2_FLEXIO08 ALT5: GPIO4_IO08	1V8	
104	A16	ENET1_RXD0	ENET1_RD0	ALT0: ENET_QOS_RGMII_RD0 ALT1: LPUART3_RX ALT4: FLEXIO2_FLEXIO10 ALT5: GPIO4_IO10	1V8	
105	A15	ENET1_RXD1	ENET1_RD1	ALT0: ENET_QOS_RGMII_RD1 ALT1: LPUART3_CTS_B ALT3: LPTMR2_ALT1 ALT4: FLEXIO2_FLEXIO11 ALT5: GPIO4_IO11	1V8	
106	A14	ENET1_RXD2	ENET1_RD2	ALT0: ENET_QOS_RGMII_RD2 ALT3: LPTMR2_ALT2 ALT4: FLEXIO2_FLEXIO12 ALT5: GPIO4_IO12	1V8	
107	A13	ENET1_RXD3	ENET1_RD3	ALT0: ENET_QOS_RGMII_RD3 ALT3: LPTMR2_ALT3 ALT4: FLEXIO2_FLEXIO13 ALT5: GPIO4_IO13	1V8	
108	A12	NC	-	-	-	
109	A11	ENET1_MDIO	ENET1_MDIO	ALT0: ENET_QOS_MDIO ALT1: LPUART3_RIN_B ALT2: I3C2_SDA ALT3: HSIOMIX_OTG_PWR1 ALT4: FLEXIO2_FLEXIO01	1V8	

Castellated pad number	Associated LGA pad name	ConnectCore 91 signal name	i.MX 91 pin name	Multiplexing (green value represents default functionality)	Power group	Comments
				ALT5: GPIO4_IO01 ALT6: LPI2C1_SDA		
110	A10	ENET1_MDC	ENET1_MDC	ALT0: ENET_QOS_MDC ALT1: LPUART3_DCB_B ALT2: I3C2_SCL ALT3: HSIOMIX_OTG_ID1 ALT4: FLEXIO2_FLEXIO00 ALT5: GPIO4_IO00 ALT6: LPI2C1_SCL	1V8	
111	A9	USB_OTG2_P	USB2_D_P			
112	A8	USB_OTG2_N	USB2_D_N			
113	A7	USB_OTG1_P	USB1_D_P			
114	A6	USB_OTG1_N	USB1_D_N			
115	-	GND				
116	B6	USB1_VBUS	USB1_VBUS			
117	D4	GND				
118	C6	USB_OTG1_ID	USB1_ID		3V3	

LGA signals and multiplexing

LGA pad name	ConnectCore 91 signal name	i.MX 91 pin name	Multiplexing <i>(green value represents default functionality)</i>	Power group	Comments
A4	GND				
A5	GND				
A6	USB_OTG1_N	USB1_D_N			
A7	USB_OTG1_P	USB1_D_P			
A8	USB_OTG2_N	USB2_D_N			
A9	USB_OTG2_P	USB2_D_P			
A10	ENET1_MDC	ENET1_MDC	ALT0: ENET_QOS_MDC ALT1: LPUART3_DCB_B ALT2: I3C2_SCL ALT3: HSIOMIX_OTG_ID1 ALT4: FLEXIO2_FLEXIO00 ALT5: GPIO4_IO00 ALT6: LPI2C1_SCL	1V8	
A11	ENET1_MDIO	ENET1_MDIO	ALT0: ENET_QOS_MDIO ALT1: LPUART3_RIN_B ALT2: I3C2_SDA ALT3: HSIOMIX_OTG_PWR1 ALT4: FLEXIO2_FLEXIO01 ALT5: GPIO4_IO01 ALT6: LPI2C1_SDA	1V8	
A12	NC	-	-	-	
A13	ENET1_RXD3	ENET1_RD3	ALT0: ENET_QOS_RGMII_RD3 ALT3: LPTMR2_ALT3	1V8	

LGA pad name	ConnectCore 91 signal name	i.MX 91 pin name	Multiplexing (green value represents default functionality)	Power group	Comments
			ALT4: FLEXIO2_FLEXIO13 ALT5: GPIO4_IO13		
A14	ENET1_RXD2	ENET1_RD2	ALT0: ENET_QOS_RGMII_RD2 ALT3: LPTMR2_ALT2 ALT4: FLEXIO2_FLEXIO12 ALT5: GPIO4_IO12	1V8	
A15	ENET1_RXD1	ENET1_RD1	ALT0: ENET_QOS_RGMII_RD1 ALT1: LPUART3_CTS_B ALT3: LPTMR2_ALT1 ALT4: FLEXIO2_FLEXIO11 ALT5: GPIO4_IO11	1V8	
A16	ENET1_RXD0	ENET1_RD0	ALT0: ENET_QOS_RGMII_RD0 ALT1: LPUART3_RX ALT4: FLEXIO2_FLEXIO10 ALT5: GPIO4_IO10	1V8	
A17	ENET1_RX_CTL	ENET1_RX_CTL	ALT0: CCM_ENET_QOS_RGMII_RX_CTL ALT1: LPUART3_DSR_B ALT2: LPSPI2_PCS0 ALT3: HSIOMIX_OTG_PWR2 ALT4: FLEXIO2_FLEXIO08 ALT5: GPIO4_IO08	1V8	
A18	ENET1_RXC	ENET1_RXC	ALT0: ENET_QOS_RGMII_RXC ALT1: ENET_QOS_RX_ER ALT2: LPSPI2_SOUT ALT4: FLEXIO2_FLEXIO09 ALT5: GPIO4_IO09	1V8	
A19	ENET1_TXD3	ENET1_TD3	ALT0: ENET_QOS_RGMII_TD3 ALT2: CAN2_TX ALT3: HSIOMIX_OTG_ID2 ALT4: FLEXIO2_FLEXIO02	1V8	

LGA pad name	ConnectCore 91 signal name	i.MX 91 pin name	Multiplexing (green value represents default functionality)	Power group	Comments
			ALT5: GPIO4_IO02 ALT6: LPI2C2_SCL		
A20	ENET1_TXD2	ENET1_TD2	ALT0: ENET_QOS_RGMII_TD2 ALT1: ENET_QOS_CLOCK_GENERATE_REF_CLK ALT2: CAN2_RX ALT3: HSIOMIX_OTG_OC2 ALT4: FLEXIO2_FLEXIO03 ALT5: GPIO4_IO03 ALT6: LPI2C2_SDA	1V8	
A21	ENET1_TXD1	ENET1_TD1	ALT0: ENET_QOS_RGMII_TD1 ALT1: LPUART3_RTS_B ALT2: I3C2_PUR ALT3: HSIOMIX_OTG_OC1 ALT4: FLEXIO2_FLEXIO04 ALT5: GPIO4_IO04 ALT6: I3C2_PUR_B	1V8	
A22	ENET1_TXD0	ENET1_TD0	ALT0: ENET_QOS_RGMII_TD0 ALT1: LPUART3_TX ALT4: FLEXIO2_FLEXIO05 ALT5: GPIO4_IO05	1V8	
A23	ENET1_TX_CTL	ENET1_TX_CTL	ALT0: ENET_QOS_RGMII_TX_CTL ALT1: LPUART3_DTR_B ALT2: LPSPI2_SCK ALT4: FLEXIO2_FLEXIO06 ALT5: GPIO4_IO06	1V8	
A24	ENET1_TXC	ENET1_TXC	ALT0: ENET_CCM_QOS_CLOCK_GENERATE_TX_CLK ALT1: ENET_QOS_TX_ER ALT2: LPSPI2_SIN	1V8	

LGA pad name	ConnectCore 91 signal name	i.MX 91 pin name	Multiplexing (green value represents default functionality)	Power group	Comments
			ALT4: FLEXIO2_FLEXIO07 ALT5: GPIO4_IO07		
A25	GND				
A26	PCM_MCLK				This line comes directly from the Wireless chip. Functionality not supported by default.
B3	GND				
B4	GND				
B5	GND				
B6	USB1_VBUS	USB1_VBUS			
B7	NC	-	-	-	
B8	GND				
B9	NC	-	-	-	
B10	NC	-	-	-	
B11	GND				
B12	NC	-	-	-	
B13	NC	-	-	-	
B14	GND				

LGA pad name	ConnectCore 91 signal name	i.MX 91 pin name	Multiplexing (green value represents default functionality)	Power group	Comments
B15	GND				
B16	NC	-	-	-	
B17	NC	-	-	-	
B18	GND				
B19	ENET2_TX_CTL	ENET2_TX_CTL	ALT0: ENET2_RGMII_TX_CTL ALT1: LPUART4_DTR_B ALT2: SAI2_TX_SYNC ALT4: FLEXIO2_FLEXIO20 ALT5: GPIO4_IO20 ALT6: MEDIAMIX_CAM_DATA03	1V8	
B20	ENET2_TXC	ENET2_TXC	ALT0: ENET2_RGMII_TXC ALT1: ENET2_TX_ER ALT2: SAI2_TX_BCLK ALT4: FLEXIO2_FLEXIO21 ALT5: GPIO4_IO21 ALT6: MEDIAMIX_CAM_DATA04	1V8	
B21	ENET2_TXD3	ENET2_TD3	ALT0: ENET2_RGMII_TD3 ALT2: SAI2_RX_DATA00 ALT4: FLEXIO2_FLEXIO16 ALT5: GPIO4_IO16 ALT6: MEDIAMIX_CAM_VSYNC	1V8	
B22	ENET2_RXD3	ENET2_RD3	ALT0: ENET2_RGMII_RD3 ALT1: SPDIF_OUT ALT2: SPDIF_IN ALT3: MQS2_LEFT ALT4: FLEXIO2_FLEXIO27 ALT5: GPIO4_IO27	1V8	
B23	NC	-	-	-	

LGA pad name	ConnectCore 91 signal name	i.MX 91 pin name	Multiplexing (green value represents default functionality)	Power group	Comments
B24	SAI3_MCLK	GPIO_IO17	ALT0: GPIO2_IO17 ALT1: SAI3_MCLK ALT2: MEDIAMIX_CAM_DATA08 ALT3: MEDIAMIX_DISP_DATA13 ALT4: LPUART3_RTS_B ALT5: LPSPI4_PCS1 ALT6: LPUART4_RTS_B ALT7: FLEXIO1_FLEXIO17	3V3	
B25	GND				
B26	GND				
B27	GND				
C2	GND				
C3	NC	-	-	-	
C4	GND				
C5	GND				
C6	USB_OTG1_ID	USB1_ID		3V3	
C7	NC	-	-	-	
C8	NC	-	-	-	
C9	NC	-	-	-	
C10	USB_OTG2_ID	USB2_ID			
C11	NC	-	-	-	
C12	GND				
C13	GND				

LGA pad name	ConnectCore 91 signal name	i.MX 91 pin name	Multiplexing (green value represents default functionality)	Power group	Comments
C14	GND				
C15	GND				
C16	GND				
C17	SPI1_CS0	SAI1_TXFS	ALT0: SAI1_TX_SYNC ALT1: SAI1_TX_DATA01 ALT2: LPSPI1_PCS0 ALT3: LPUART2_DTR_B ALT4: MQS1_LEFT ALT5: GPIO1_IO11	3V3	
C18	SPI1_SIN	SAI1_TXC	ALT0: SAI1_TX_BCLK ALT1: LPUART2_CTS_B ALT2: LPSPI1_SIN ALT3: LPUART1_DSR_B ALT4: CAN1_RX ALT5: GPIO1_IO12	3V3	
C19	SAI3_TXFS	GPIO_IO26	ALT0: GPIO2_IO26 ALT1: USDHC3_DATA2 ALT2: PDM_BIT_STREAM01 ALT3: MEDIAMIX_DISP_DATA22 ALT4: TPM5_CH3 ALT5: JTAG_MUX_TDI ALT6: LPSPI8_PCS1 ALT7: SAI3_TX_SYNC	3V3	
C20	ENET2_RXD2	ENET2_RD2	ALT0: ENET2_RGMII_RD2 ALT1: LPUART4_CTS_B ALT2: SAI2_MCLK ALT3: MQS2_RIGHT ALT4: FLEXIO2_FLEXIO26 ALT5: GPIO4_IO26 ALT6: MEDIAMIX_CAM_DATA09	1V8	

LGA pad name	ConnectCore 91 signal name	i.MX 91 pin name	Multiplexing (green value represents default functionality)	Power group	Comments
C21	ENET2_TXD2	ENET2_TD2	ALT0: ENET2_RGMII_TD2 ALT1: ENET2_TX_CLK ALT4: FLEXIO2_FLEXIO17 ALT5: GPIO4_IO17 ALT6: MEDIAMIX_CAM_HSYNC	1V8	
C22	ENET2_TXD0	ENET2_TD0	ALT0: ENET1_RGMII_TDO ALT1: LPUART4_TX ALT4: FLEXIO2_FLEXIO19 ALT5: GPIO4_IO19 ALT6: MEDIAMIX_CAM_DATA02	1V8	
C23	ENET2_RX_CTL	ENET2_RX_CTL	ALT0: ENET2_RGMII_RX_CTL ALT1: LPUART4_DSR_B ALT2: SAI2_TX_DATA00 ALT4: FLEXIO2_FLEXIO22 ALT5: GPIO4_IO22 ALT6: MEDIAMIX_CAM_DATA05	1V8	
C24	GPIO2_IO24	GPIO_IO24	ALT0: GPIO2_IO24 ALT1: USDHC3_DATA0 ALT3: MEDIAMIX_DISP_DATA20 ALT4: TPM3_CH3 ALT5: JTAG_MUX_TDO ALT6: LPSPI6_PCS1 ALT7: FLEXIO1_FLEXIO24	3V3	
C25	GND				
C26	GND				
C27	RF_ANT_EXT				Internal antenna pad.
C28	GND				

LGA pad name	ConnectCore 91 signal name	i.MX 91 pin name	Multiplexing (green value represents default functionality)	Power group	Comments
D1	NC	-	-	-	
D2	GND				
D3	GND				
D4	GND				
D5	WLAN_SD3_DATA3	SD3_DATA3	ALT0: USDHC3_DATA3 ALT1: FLEXSPI1_A_DATA03 ALT2: LPI2C4_SCL ALT4: FLEXIO1_FLEXIO25 ALT5: GPIO3_IO25	1V8	This SDIO interface is connected to the Wireless chip on the wireless variants of the SOM.
D6	WLAN_SD3_DATA2	SD3_DATA2	ALT0: USDHC3_DATA2 ALT1: FLEXSPI1_A_DATA02 ALT2: LPI2C4_SDA ALT4: FLEXIO1_FLEXIO24 ALT5: GPIO3_IO24	1V8	This pads must remain unconnected unless when using a non wireless variant of the module.
D7	NC	-	-	-	
D8	WLAN_SD3_DATA1	SD3_DATA1	ALT0: USDHC3_DATA1 ALT1: FLEXSPI1_A_DATA01 ALT2: LPUART2_RTS_B ALT4: FLEXIO1_FLEXIO23 ALT5: GPIO3_IO23	1V8	This SDIO interface is connected to the Wireless chip on the wireless variants of the SOM.

LGA pad name	ConnectCore 91 signal name	i.MX 91 pin name	Multiplexing (green value represents default functionality)	Power group	Comments
					This pads must remain unconnected unless when using a non wireless variant of the module.
D9	WLAN_SD3_DATA0	SD3_DATA0	ALT0: USDHC3_DATA0 ALT1: FLEXSPI1_A_DATA00 ALT2: LPUART2_CTS_B ALT4: FLEXIO1_FLEXIO22 ALT5: GPIO3_IO22	1V8	
D10	NC	-	-	-	
D11	WLAN_SD3_CMD	SD3_CMD	ALT0: USDHC3_CMD ALT1: FLEXSPI1_A_SS0_B ALT2: LPUART1_RTS_B ALT4: FLEXIO1_FLEXIO21 ALT5: GPIO3_IO21	1V8	This SDIO interface is connected to the Wireless chip on the wireless variants of the SOM.
D12	WLAN_SD3_CLK	SD3_CLK	ALT0: USDHC3_CLK ALT1: FLEXSPI1_A_SCLK ALT2: LPUART1_CTS_B ALT4: FLEXIO1_FLEXIO20 ALT5: GPIO3_IO20	1V8	This pads must remain unconnected unless when using a non wireless variant of the module.
D13	NC	-	-	-	
D14	NC	-	-	-	
D15	NC	-	-	-	
D16	GND				

LGA pad name	ConnectCore 91 signal name	i.MX 91 pin name	Multiplexing (green value represents default functionality)	Power group	Comments
D17	SPI8_SCK	GPIO_IO15	ALT0: GPIO2_IO15 ALT1: LPUART3_RX ALT2: MEDIAMIX_CAM_DATA07 ALT3: MEDIAMIX_DISP_DATA11 ALT4: LPSPI8_SCK ALT5: LPUART8_RTS_B ALT6: LPUART4_RX ALT7: FLEXIO1_FLEXIO15	3V3	
D18	SPI1_SOUT	SAI1_RXD0	ALT0: SAI1_RX_DATA00 ALT1: SAI1_MCLK ALT2: LPSPI1_SOUT ALT3: LPUART2_DSR_B ALT4: MQS1_RIGHT ALT5: GPIO1_IO14	3V3	
D19	NC	-	-	-	
D20	ENET2_TXD1	ENET2_TD1	ALT0: ENET2_RGMII_TD1 ALT1: LPUART4_RTS_B ALT4: FLEXIO2_FLEXIO18 ALT5: GPIO4_IO18 ALT6: MEDIAMIX_CAM_DATA01	1V8	
D21	ENET2_RXD0	ENET2_RD0	ALT0: ENET2_RGMII_RD0 ALT1: LPUART4_RX ALT4: FLEXIO2_FLEXIO24 ALT5: GPIO4_IO24 ALT6: MEDIAMIX_CAM_DATA07	1V8	
D22	ENET2_RXC	ENET2_RXC	ALT0: ENET2_RGMII_RXC ALT1: ENET2_RX_ER ALT4: FLEXIO2_FLEXIO23 ALT5: GPIO4_IO23 ALT6: MEDIAMIX_CAM_DATA06	1V8	

LGA pad name	ConnectCore 91 signal name	i.MX 91 pin name	Multiplexing (green value represents default functionality)	Power group	Comments
D23	ENET2_RXD1	ENET2_RD1	ALT0: ENET2_RGMII_RD1 ALT1: SPDIF_IN ALT4: FLEXIO2_FLEXIO25 ALT5: GPIO4_IO25 ALT6: MEDIAMIX_CAM_DATA08	1V8	
D24	GND				
D25	GPIO3_IO27 (1V8)	CCM_CLKO2	ALT0: CCMSRCGPCMIX_CLKO2 ALT4: FLEXIO1_FLEXIO27 ALT5: GPIO3_IO27	Internal 1.8 V supply	
D26	GND				
D27	GND				
D28	GND				
D29	GND				
E1	GND				
E2	GND				
E3	GPIO2_IO19	GPIO_IO19	ALT0: GPIO2_IO19 ALT1: SAI3_RX_SYNC ALT2: PDM_BIT_STREAM03 ALT3: MEDIAMIX_DISP_DATA15 ALT4: LPSPI5_SIN ALT5: LPSPI4_SIN ALT6: TPM6_CH2 ALT7: SAI3_TX_DATA00	3V3	
E4	SD2_RESET_B	SD2_RESET_B	ALT0: USDHC2_RESET_B ALT1: LPTMR2_ALT2 ALT4: FLEXIO1_FLEXIO07 ALT5: GPIO3_IO07	NVCC_SD2	

LGA pad name	ConnectCore 91 signal name	i.MX 91 pin name	Multiplexing (green value represents default functionality)	Power group	Comments
			ALT6: CCMSRCGPCMIX_SYSTEM_RESET		
E5	1V8				
E6	GND				
E7	USB2_VBUS	USB2_VBUS			
E8	GND				
E9	IW612_JTAG_TDI				This line comes directly from the Wireless chip. Functionality not supported by default.
E10	IW612_JTAG_TMS				
E11	IW612_JTAG_TCK				
E12	BT_UART1_RXD	UART1_RXD	ALT0: LPUART1_RX ALT1: ELE_UART_RX ALT2: LPSPI2_SIN ALT3: TPM1_CH0 ALT5: GPIO1_IO04	3V3	Internal UART line used by the Bluetooth. This signal is externally available only in non-wireless variants.
E13	BT_UART1_TXD	UART1_TXD	ALT0: LPUART1_TX ALT1: ELE_UART_TX ALT2: LPSPI2_PCS0 ALT3: TPM1_CH1 ALT5: GPIO1_IO05	3V3	
E14	SWIN				
E15	GND				
E16	NC	-	-	-	
E17	SPI1_SCK	SAI1_TXD0	ALT0: SAI1_TX_DATA00	3V3	

LGA pad name	ConnectCore 91 signal name	i.MX 91 pin name	Multiplexing (green value represents default functionality)	Power group	Comments
			ALT1: LPUART2_RTS_B ALT2: LPSPI1_SCK ALT3: LPUART1_DTR_B ALT4: CAN1_TX ALT5: GPIO1_IO13 ALT6: SAI1_MCLK		
E18	SPI8_SOUT	GPIO_IO14	ALT0: GPIO2_IO14 ALT1: LPUART3_TX ALT2: MEDIAMIX_CAM_DATA06 ALT3: MEDIAMIX_DISP_DATA10 ALT4: LPSPI8_SOUT ALT5: LPUART8_CTS_B ALT6: LPUART4_TX ALT7: FLEXIO1_FLEXIO14	3V3	
E19	SPI8_CS0	GPIO_IO12	ALT0: GPIO2_IO12 ALT1: TPM3_CH2 ALT2: PDM_BIT_STREAM02 ALT3: MEDIAMIX_DISP_DATA08 ALT4: LPSPI8_PCS0 ALT5: LPUART8_TX ALT6: LPI2C8_SDA ALT7: SAI3_RX_SYNC	3V3	
E20	SAI3_TXD	GPIO_IO21	ALT0: GPIO2_IO21 ALT1: SAI3_TX_DATA00 ALT2: PDM_CLK ALT3: MEDIAMIX_DISP_DATA17 ALT4: LPSPI5_SCK ALT5: LPSPI4_SCK ALT6: TPM4_CH1 ALT7: SAI3_RX_BCLK	3V3	
E21	SAI3_RXD	GPIO_IO20	ALT0: GPIO2_IO20	3V3	

LGA pad name	ConnectCore 91 signal name	i.MX 91 pin name	Multiplexing (green value represents default functionality)	Power group	Comments
			ALT1: SAI3_RX_DATA00 ALT2: PDM_BIT_STREAM00 ALT3: MEDIAMIX_DISP_DATA16 ALT4: LPSPI5_SOUT ALT5: LPSPI4_SOUT ALT6: TPM3_CH1 ALT7: FLEXIO1_FLEXIO20		
E22	SPI8_SIN	GPIO_IO13	ALT0: GPIO2_IO13 ALT1: TPM4_CH2 ALT2: PDM_BIT_STREAM03 ALT3: MEDIAMIX_DISP_DATA09 ALT4: LPSPI8_SIN ALT5: LPUART8_RX ALT6: LPI2C8_SCL ALT7: FLEXIO1_FLEXIO13	3V3	
E23	SAI3_TXC	GPIO_IO16	ALT0: GPIO2_IO16 ALT1: SAI3_TX_BCLK ALT2: PDM_BIT_STREAM02 ALT3: MEDIAMIX_DISP_DATA12 ALT4: LPUART3_CTS_B ALT5: LPSPI4_PCS2 ALT6: LPUART4_CTS_B ALT7: FLEXIO1_FLEXIO16	3V3	
E24	NC	-	-	-	
E25	NC	-	-	-	
E26	NC	-	-	-	
E27	GPIO2_IO23	GPIO_IO23	ALT0: GPIO2_IO23 ALT1: USDHC3_CMD ALT2: SPDIF_OUT ALT3: MEDIAMIX_DISP_DATA19	3V3	

LGA pad name	ConnectCore 91 signal name	i.MX 91 pin name	Multiplexing (green value represents default functionality)	Power group	Comments
			ALT4: TPM6_CH1 ALT6: LPI2C5_SCL ALT7: FLEXIO1_FLEXIO23		
E28	GPIO2_IO22	GPIO_IO22	ALT0: GPIO2_IO22 ALT1: USDHC3_CLK ALT2: SPDIF_IN ALT3: MEDIAMIX_DISP_DATA18 ALT4: TPM5_CH1 ALT5: TPM6_EXTCLK ALT6: LPI2C5_SDA ALT7: FLEXIO1_FLEXIO22	3V3	
E29	I2C4_SDA	GPIO_IO02	ALT0: GPIO2_IO02 ALT1: LPI2C4_SDA ALT2: MEDIAMIX_CAM_VSYNC ALT3: MEDIAMIX_DISP_VSYNC ALT4: LPSP16_SOUT ALT5: LPUART5_CTS_B ALT6: LPI2C6_SDA ALT7: FLEXIO1_FLEXIO02	3V3	
F1	SD2_CMD	SD2_CMD	ALT0: USDHC2_CMD ALT1: ENET1_1588_EVENT0_IN ALT2: I3C2_PUR ALT3: I3C2_PUR_B ALT4: FLEXIO1_FLEXIO02 ALT5: GPIO3_IO02	NVCC_SD2	
F2	SW_EN				
F3	NC	-	-	-	

LGA pad name	ConnectCore 91 signal name	i.MX 91 pin name	Multiplexing (green value represents default functionality)	Power group	Comments
F4	15.4_SPI_FRM				This line comes directly from the Wireless chip. Functionality not supported by default.
F5	15.4_SPI_INT				
F6	15.4_SPI_RXD				
F7	15.4_SPI_TXD				
F8	15.4_SPI_CLK				
F9	NC	-	-	-	
F10	NC	-	-	-	
F11	BT_UART1_RTS#	UART2_TXD	ALT0: LPUART2_TX ALT1: LPUART1_RTS_B ALT2: LPSPI2_SCK ALT3: TPM1_CH3 ALT5: GPIO1_IO07 ALT7: SAI3_TX_SYNC	3V3	Internal UART line used by the Bluetooth. This signal is externally available only in non-wireless variants.
F12	BT_UART1_CTS#	UART2_RXD	ALT0: LPUART2_RX ALT1: LPUART1_CTS_B ALT2: LPSPI2_SOUT ALT3: TPM1_CH2 ALT4: SAI1_MCLK ALT5: GPIO1_IO06	3V3	
F13	PCM_OUT				This line comes directly from the Wireless chip. Functionality not supported by default.
F14	PCM_SYNC				

LGA pad name	ConnectCore 91 signal name	i.MX 91 pin name	Multiplexing (green value represents default functionality)	Power group	Comments
F15	GND				
F16	GND				
F17	3V3_RF				
F18	3V3_RF				
F19	NC	-	-	-	
F20	MUX_3V3_1V8				
F21	GND				
F22	GND				
F23	NC	-	-	-	
F24	WL_DEV_WAKE				
F25	NC	-	-	-	
F26	NC	-	-	-	
F27	NC	-	-	-	
F28	I2C4_SCL	GPIO_IO03	ALT0: GPIO2_IO03 ALT1: LPI2C4_SCL ALT2: MEDIAMIX_CAM_HSYNC ALT3: MEDIAMIX_DISP_HSYNC ALT4: LPSPI6_SCK ALT5: LPUART5_RTS_B ALT6: LPI2C6_SCL ALT7: FLEXIO1_FLEXIO03	3V3	
F29	TAMPER1 (1V8)	TAMPER1		Internal 1.8 V supply	

LGA pad name	ConnectCore 91 signal name	i.MX 91 pin name	Multiplexing (green value represents default functionality)	Power group	Comments
G1	SD2_DATA0	SD2_DATA0	ALT0: USDHC2_DATA0 ALT1: ENET2_1588_EVENT0_OUT ALT2: CAN2_TX ALT3: LPUART1_TX ALT4: FLEXIO1_FLEXIO03 ALT5: GPIO3_IO03	NVCC_ SD2	
G2	SD2_CD_B	SD2_CD_B	ALT0: USDHC2_CD_B ALT1: ENET_QOS_1588_EVENT0_IN ALT2: I3C2_SCL ALT3: LPI2C1_SCL ALT4: FLEXIO1_FLEXIO00 ALT5: GPIO3_IO00	NVCC_ SD2	
G3	NC	-	-	-	
G4	NC	-	-	-	
G5	GND				
G6	NC	-	-	-	
G7	NC	-	-	-	
G8	GND				
G9	NC	-	-	-	
G10	NC	-	-	-	
G11	GND				
G12	BT_DEV_WAKE				

LGA pad name	ConnectCore 91 signal name	i.MX 91 pin name	Multiplexing (green value represents default functionality)	Power group	Comments
G13	PCM_CLK				This line comes directly from the Wireless chip. Functionality not supported by default.
G14	PCM_IN				
G15	IW612_JTAG_TDO				
G16	GND				
G17	BT_HOST_WAKE				
G18	WL_HOST_WAKE				
G19	GND				
G20	NC	-	-	-	
G21	NC	-	-	-	
G22	GND				
G23	NC	-	-	-	
G24	NC	-	-	-	
G25	GND				
G26	GND				
G27	GND				
G28	GND				
G29	TAMPER0 (1V8)	TAMPER0		Internal 1.8 V supply	

LGA pad name	ConnectCore 91 signal name	i.MX 91 pin name	Multiplexing (green value represents default functionality)	Power group	Comments
H1	SD2_DATA1	SD2_DATA1	ALT0: USDHC2_DATA1 ALT1: ENET2_1588_EVENT1_IN ALT2: CAN2_RX ALT3: LPUART1_RX ALT4: FLEXIO1_FLEXIO04 ALT5: GPIO3_IO04	NVCC_ SD2	
H2	GND				
H3	GND				
H4	GND				
H5	GND				
H6	GND				
H7	GND				
H8	GND				
H9	GND				
H10	GND				
H11	GND				
H12	GND				
H13	GND				
H14	GND				
H15	GND				
H16	GND				
H17	GND				

LGA pad name	ConnectCore 91 signal name	i.MX 91 pin name	Multiplexing (green value represents default functionality)	Power group	Comments
H18	GND				
H19	GND				
H20	GND				
H21	GND				
H22	GND				
H23	GND				
H24	GND				
H25	GND				
H26	GND				
H27	GND				
H28	GND				
H29	GND				
J1	SD2_DATA2	SD2_DATA2	ALT0: USDHC2_DATA2 ALT1: ENET2_1588_EVENT1_OUT ALT2: MQS2_RIGHT ALT3: LPUART2_TX ALT4: FLEXIO1_FLEXIO05 ALT5: GPIO3_IO05	NVCC_ SD2	
J29	NC	-	-	-	
K1	SD2_DATA3	SD2_DATA3	ALT0: USDHC2_DATA3 ALT1: LPTMR2_ALT1 ALT2: MQS2_LEFT ALT3: LPUART2_RX ALT4: FLEXIO1_FLEXIO06	NVCC_ SD2	

LGA pad name	ConnectCore 91 signal name	i.MX 91 pin name	Multiplexing (green value represents default functionality)	Power group	Comments
			ALT5: GPIO3_IO06		
K29	ADC_IN0 (1V8)	ADC_IN0			
L1	SD2_CLK	SD2_CLK	ALT0: USDHC2_CLK ALT1: ENET_QOS_1588_EVENT0_OUT ALT2: I3C2_SDA ALT3: I2C1_SDA ALT4: FLEXIO1_FLEXIO01 ALT5: GPIO3_IO01	NVCC_SD2	
L29	ADC_IN1 (1V8)	ADC_IN1			
M1	GND				
M29	UART7_CTS	GPIO_IO10	ALT0: GPIO2_IO10 ALT1: LPSPI3_SOUT ALT2: MEDIAMIX_CAM_DATA04 ALT3: MEDIAMIX_DISP_DATA06 ALT4: TPM4_EXTCLK ALT5: LPUART7_CTS_B ALT6: LPI2C8_SDA ALT7: FLEXIO1_FLEXIO10	3V3	
N1	NVCC_SD2				
N29	UART7_RTS	GPIO_IO11	ALT0: GPIO2_IO11 ALT1: LPSPI3_SCK ALT2: MEDIAMIX_CAM_DATA05 ALT3: MEDIAMIX_DISP_DATA07 ALT4: TPM5_EXTCLK ALT5: LPUART7_RTS_B ALT6: LPI2C8_SCL ALT7: FLEXIO1_FLEXIO11	3V3	
P1	UART7_TX	GPIO_IO08	ALT0: GPIO2_IO08	3V3	

LGA pad name	ConnectCore 91 signal name	i.MX 91 pin name	Multiplexing (green value represents default functionality)	Power group	Comments
			ALT1: LPSPI3_PCS0 ALT2: MEDIAMIX_CAM_DATA02 ALT3: MEDIAMIX_DISP_DATA04 ALT4: TPM6_CH0 ALT5: LPUART7_TX ALT6: LPI2C7_SDA ALT7: FLEXIO1_FLEXIO08		
P29	CAN2_TX	GPIO_IO25	ALT0: GPIO2_IO25 ALT1: USDHC3_DATA1 ALT2: CAN2_TX ALT3: MEDIAMIX_DISP_DATA21 ALT4: TPM4_CH3 ALT5: JTAG_MUX_TCK ALT6: LPSPI7_PCS1 ALT7: FLEXIO1_FLEXIO25	3V3	
R1	UART7_RX	GPIO_IO09	ALT0: GPIO2_IO09 ALT1: LPSPI3_SIN ALT2: MEDIAMIX_CAM_DATA03 ALT3: MEDIAMIX_DISP_DATA05 ALT4: TPM3_EXTCLK ALT5: LPUART7_RX ALT6: LPI2C7_SCL ALT7: FLEXIO1_FLEXIO09	3V3	
R29	CAN2_RX	GPIO_IO27	ALT0: GPIO2_IO27 ALT1: USDHC3_DATA3 ALT2: CAN2_RX ALT3: MEDIAMIX_DISP_DATA23 ALT4: TPM6_CH3 ALT5: JTAG_MUX_TMS ALT6: LPSPI5_PCS1 ALT7: FLEXIO1_FLEXIO27	3V3	

LGA pad name	ConnectCore 91 signal name	i.MX 91 pin name	Multiplexing (green value represents default functionality)	Power group	Comments
T1	GND				
T29	CAN1_TX	PDM_CLK	ALT0: PDM_CLK ALT1: MQS1_LEFT ALT4: LPTMR1_ALT1 ALT5: GPIO1_IO08 ALT6: CAN1_TX	3V3	
U1	NC	-	-	-	
U29	CAN1_RX	PDM_BIT_STREAM0	ALT0: PDM_BIT_STREAM00 ALT1: MQS1_RIGHT ALT2: LPSPI1_PCS1 ALT3: TPM1_EXTCLK ALT4: LPTMR1_ALT2 ALT5: GPIO1_IO09 ALT6: CAN1_RX	3V3	
V1	I2C2_SCL	I2C2_SCL	ALT0: LPI2C2_SCL ALT1: I3C1_PUR ALT2: LPUART2_DCB_B ALT3: TPM2_CH2 ALT4: SAI1_RX_SYNC ALT5: GPIO1_IO02 ALT6: I3C1_PUR_B	3V3	
V29	UART6_RX	GPIO_IO05	ALT0: GPIO2_IO05 ALT1: TPM4_CH0 ALT2: PDM_BIT_STREAM00 ALT3: MEDIAMIX_DISP_DATA01 ALT4: LPSPI7_SIN ALT5: LPUART6_RX ALT6: LPI2C6_SCL ALT7: FLEXIO1_FLEXIO05	3V3	
W1	I2C2_SDA	I2C2_SDA	ALT0: LPI2C2_SDA	3V3	

LGA pad name	ConnectCore 91 signal name	i.MX 91 pin name	Multiplexing (green value represents default functionality)	Power group	Comments
			ALT2: LPUART2_RIN_B ALT3: TPM2_CH3 ALT4: SAI1_RX_BCLK ALT5: GPIO1_IO03		
W29	UART6_TX	GPIO_IO04	ALT0: GPIO2_IO04 ALT1: TPM3_CH0 ALT2: PDM_CLK ALT3: MEDIAMIX_DISP_DATA00 ALT4: LPSPI7_PCS0 ALT5: LPUART6_TX ALT6: LPI2C6_SDA ALT7: FLEXIO1_FLEXIO04	3V3	
Y1	PDM_BIT_STREAM1	PDM_BIT_STREAM1	ALT0: PDM_BIT_STREAM01 ALT2: LPSPI2_PCS1 ALT3: TPM2_EXTCLK ALT4: LPTMR1_ALT3 ALT5: GPIO1_IO10	3V3	
Y29	GND				
AA1	GPIO2_IO06	GPIO_IO06	ALT0: GPIO2_IO06 ALT1: TPM5_CH0 ALT2: PDM_BIT_STREAM01 ALT3: MEDIAMIX_DISP_DATA02 ALT4: LPSPI7_SOUT ALT5: LPUART6_CTS_B ALT6: LPI2C7_SDA ALT7: FLEXIO1_FLEXIO06	3V3	
AA29	NC	-	-	-	
AB1	NC	-	-	-	
AB29	NC	-	-	-	

LGA pad name	ConnectCore 91 signal name	i.MX 91 pin name	Multiplexing (green value represents default functionality)	Power group	Comments
AC1	NC	-	-	-	
AC29	NC	-	-	-	
AD1	NC	-	-	-	
AD29	NC	-	-	-	
AE1	NC	-	-	-	
AE29	NC	-	-	-	
AF1	GPIO4_IO14 (1V8)	ENET2_MDC	ALT0: ENET2_MDC ALT1: LPUART4_DCB_B ALT2: SAI2_RX_SYNC ALT4: FLEXIO2_FLEXIO14 ALT5: GPIO4_IO14 ALT6: MEDIAMIX_CAM_CLK	1V8	
AF2	GND				
AF3	GND				
AF4	GND				
AF5	GND				
AF6	GND				
AF7	GND				
AF8	GND				
AF9	GND				
AF10	GND				
AF11	GND				

LGA pad name	ConnectCore 91 signal name	i.MX 91 pin name	Multiplexing (green value represents default functionality)	Power group	Comments
AF12	GND				
AF13	GND				
AF14	GND				
AF15	GND				
AF16	GND				
AF17	GND				
AF18	GND				
AF19	GND				
AF20	GND				
AF21	GND				
AF22	GND				
AF23	GND				
AF24	GND				
AF25	GND				
AF26	GND				
AF27	GND				
AF28	GND				
AF29	NC	-	-	-	
AG1	GPIO4_IO15 (1V8)	ENET2_MDIO	ALT0: ENET2_MDIO ALT1: LPUART4_RIN_B ALT2: SAI2_RX_BCLK	1V8	

LGA pad name	ConnectCore 91 signal name	i.MX 91 pin name	Multiplexing (green value represents default functionality)	Power group	Comments
			ALT4: FLEXIO2_FLEXIO15 ALT5: GPIO4_IO15 ALT6: MEDIAMIX_CAM_DATA00		
AG2	GND				
AG3	GND				
AG4	GND				
AG5	GND				
AG6	GND				
AG7	GND				
AG8	NC	-	-	-	
AG9	NC	-	-	-	
AG10	NC	-	-	-	
AG11	NC	-	-	-	
AG12	NC	-	-	-	
AG13	NC	-	-	-	
AG14	NC	-	-	-	
AG15	NC	-	-	-	
AG16	GND				
AG17	SWOUT				
AG18	ON_OFF	ONOFF		Internal 1.8 V supply	ON/OFF signal from the CPU (active

LGA pad name	ConnectCore 91 signal name	i.MX 91 pin name	Multiplexing (green value represents default functionality)	Power group	Comments
					low).
AG19	NC	-	-	-	
AG20	JTAG_TCK	JTAG_TCK			
AG21	JTAG_TDO	JTAG_TDO			
AG22	NC	-	-	-	
AG23	GND				
AG24	NC	-	-	-	
AG25	GPIO4_IO28 (1V8)	CCM_CLKO3	ALT0: CCMSRCGPCMIX_CLKO3 ALT4: FLEXIO2_FLEXIO28 ALT5: GPIO4_IO28	Internal 1.8 V supply	
AG26	ADC_IN3 (1V8)	ADC_IN3			
AG27	ADC_IN2 (1V8)	ADC_IN2			
AG28	GPIO4_IO29 (1V8)	CCM_CLKO4	ALT0: CCMSRCGPCMIX_CLKO4 ALT4: FLEXIO2_FLEXIO29 ALT5: GPIO4_IO29	Internal 1.8 V supply	
AG29	NC	-	-	-	
AH1	1V8				
AH2	1V8				
AH3	1V8				
AH4	GND				
AH5	GND				

LGA pad name	ConnectCore 91 signal name	i.MX 91 pin name	Multiplexing (green value represents default functionality)	Power group	Comments
AH6	RTC_RESET_B				
AH7	NC	-	-	-	
AH8	GND				
AH9	NC	-	-	-	
AH10	POR_B	POR_B			
AH11	NC	-	-	-	
AH12	WDOG_B				
AH13	SD_VSELECT				
AH14	GND				
AH15	LVDS_D2_P	LVDS_D2_P			
AH16	LVDS_D2_N	LVDS_D2_N			
AH17	GND				
AH18	NC	-	-	-	
AH19	GND				
AH20	NC	-	-	-	
AH21	GND				
AH22	NC	-	-	-	
AH23	NC	-	-	-	
AH24	NC	-	-	-	
AH25	NC	-	-	-	

LGA pad name	ConnectCore 91 signal name	i.MX 91 pin name	Multiplexing (green value represents default functionality)	Power group	Comments
AH26	NC	-	-	-	
AH27	JTAG_TDI				
AH28	JTAG_TMS				
AH29	NC	-	-	-	
AJ1	GND				
AJ2	VSYS2				
AJ3	VSYS2				
AJ4	VSYS2				
AJ5	GND				
AJ6	GND				
AJ7	GND				
AJ8	NC	-	-	-	
AJ9	GND				
AJ10	NC	-	-	-	
AJ11	PMIC_STANDBY				
AJ12	PWR_ON				
AJ13	NC	-	-	-	
AJ14	GND				
AJ15	LVDS_D0_N	LVDS_D0_N			
AJ16	LVDS_D0_P	LVDS_D0_P			

LGA pad name	ConnectCore 91 signal name	i.MX 91 pin name	Multiplexing (green value represents default functionality)	Power group	Comments
AJ17	GND				
AJ18	LVDS_CLK_P	LVDS_CLK_P			
AJ19	LVDS_CLK_N	LVDS_CLK_N			
AJ20	GND				
AJ21	NC	-	-	-	
AJ22	NC	-	-	-	
AJ23	NC	-	-	-	
AJ24	NC	-	-	-	
AJ25	NC	-	-	-	
AJ26	GND				
AJ27	NC	-	-	-	
AJ28	NC	-	-	-	
AJ29	NC	-	-	-	
AK1	3V3				
AK2	VSYS2				
AK3	VSYS2				
AK4	VSYS2				
AK5	GND				
AK6	GND				
AK7	GND				

LGA pad name	ConnectCore 91 signal name	i.MX 91 pin name	Multiplexing (green value represents default functionality)	Power group	Comments
AK8	GND				
AK9	GND				
AK10	GND				
AK11	GND				
AK12	GND				
AK13	GND				
AK14	GND				
AK15	LVDS_D1_N	LVDS_D1_N			
AK16	LVDS_D1_P	LVDS_D1_P			
AK17	GND				
AK18	LVDS_D3_P	LVDS_D3_P			
AK19	LVDS_D3_N	LVDS_D3_N			
AK20	GND				
AK21	NC	-	-	-	
AK22	NC	-	-	-	
AK23	GND				
AK24	I2C3_SDA	GPIO_IO00	ALT0: GPIO2_IO00 ALT1: LPI2C3_SDA ALT2: MEDIAMIX_CAM_CLK ALT3: MEDIAMIX_DISP_CLK ALT4: LPSP16_PCS0 ALT5: LPUART5_TX ALT6: LPI2C5_SDA	3V3	

LGA pad name	ConnectCore 91 signal name	i.MX 91 pin name	Multiplexing (green value represents default functionality)	Power group	Comments
			ALT7: FLEXIO1_FLEXIO00		
AK25	I2C3_SCL	GPIO_IO01	ALT0: GPIO2_IO01 ALT1: LPI2C3_SCL ALT2: MEDIAMIX_CAM_DATA00 ALT3: MEDIAMIX_DISP_DE ALT4: LPSPI6_SIN ALT5: LPUART5_RX ALT6: LPI2C5_SCL ALT7: FLEXIO1_FLEXIO01	3V3	
AK26	NC	-	-	-	
AK27	NC	-	-	-	
AK28	NC	-	-	-	
AK29	NC	-	-	-	
AL2	3V3				
AL3	3V3				
AL4	GND				
AL5	GND				
AL6	VSYS				
AL7	VSYS				
AL8	VSYS				
AL9	GND				
AL10	GND				
AL11	GND				

LGA pad name	ConnectCore 91 signal name	i.MX 91 pin name	Multiplexing (green value represents default functionality)	Power group	Comments
AL12	NC	-	-	-	
AL13	NC	-	-	-	
AL14	GND				
AL15	NC	-	-	-	
AL16	NC	-	-	-	
AL17	GND				
AL18	GPIO3_IO26 (1V8)	CCM_CLKO1	ALT0: CCMSRCGPCMIX_CLKO1 ALT4: FLEXIO1_FLEXIO26 ALT5: GPIO3_IO26	Internal 1.8 V supply	
AL19	RESERVED				
AL20	RESERVED				
AL21	NC	-	-	-	
AL22	NC	-	-	-	
AL23	NC	-	-	-	
AL24	NC	-	-	-	
AL25	NC	-	-	-	
AL26	NC	-	-	-	
AL27	NC	-	-	-	
AL28	NC	-	-	-	
AM3	3V3				

LGA pad name	ConnectCore 91 signal name	i.MX 91 pin name	Multiplexing (green value represents default functionality)	Power group	Comments
AM4	3V3				
AM5	GND				
AM6	GND				
AM7	NC	-	-	-	
AM8	NC	-	-	-	
AM9	NC	-	-	-	
AM10	CLKIN1				
AM11	CLKIN2				
AM12	GND				
AM13	NC	-	-	-	
AM14	NC	-	-	-	
AM15	GND				
AM16	NC	-	-	-	
AM17	NC	-	-	-	
AM18	GND				
AM19	RESERVED				
AM20	GND				
AM21	NC	-	-	-	
AM22	RESERVED				
AM23	NC	-	-	-	

LGA pad name	ConnectCore 91 signal name	i.MX 91 pin name	Multiplexing (green value represents default functionality)	Power group	Comments
AM24	NC	-	-	-	
AM25	NC	-	-	-	
AM26	NC	-	-	-	
AM27	NC	-	-	-	
AN4	GPIO2_IO18	GPIO_IO18	ALT0: GPIO2_IO18 ALT1: SAI3_RX_BCLK ALT2: MEDIAMIX_CAM_DATA09 ALT3: MEDIAMIX_DISP_DATA14 ALT4: LPSPI5_PCS0 ALT5: LPSPI4_PCS0 ALT6: TPM5_CH2 ALT7: FLEXIO1_FLEXIO18	3V3	
AN5	SD2_VSELECT	SD2_VSELECT	ALT0: USDHC2_VSELECT ALT1: USDHC3_WP ALT2: LPTMR2_ALT3 ALT4: FLEXIO1_FLEXIO19 ALT5: GPIO3_IO19	1V8	
AN6	NC	-	-	-	
AN7	NC	-	-	-	
AN8	GND				
AN9	NC	-	-	-	
AN10	NC	-	-	-	
AN11	GND				
AN12	NC	-	-	-	

LGA pad name	ConnectCore 91 signal name	i.MX 91 pin name	Multiplexing (green value represents default functionality)	Power group	Comments
AN13	NC	-	-	-	
AN14	GND				
AN15	NC	-	-	-	
AN16	NC	-	-	-	
AN17	GND				
AN18	NC	-	-	-	
AN19	NC	-	-	-	
AN20	GND				
AN21	NC	-	-	-	
AN22	NC	-	-	-	
AN23	NC	-	-	-	
AN24	NC	-	-	-	
AN25	SYS_RESET			Internal 1.8 V supply	Reset line of the module (active low).
AN26	NC	-	-	-	

Module specifications

The following sections describe the specifications for the ConnectCore 91 SOM.

Mechanical specifications81

Mechanical specifications

Host PCB footprint and cutout

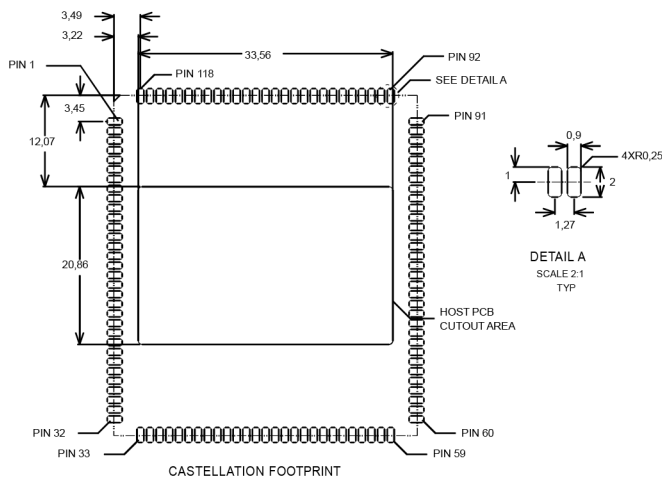
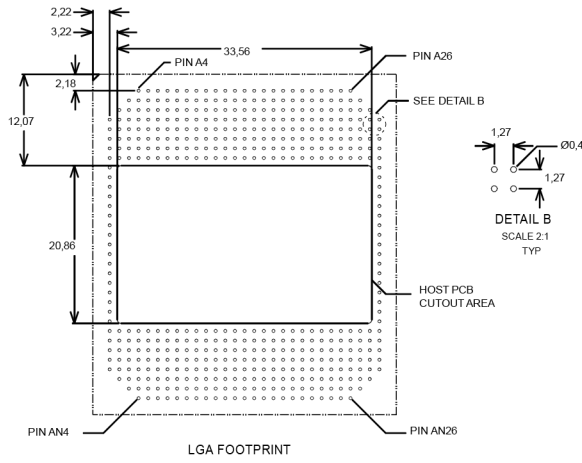

Label

The MAC address and serial number of the SOM are encoded in the data matrix on the SOM label.

Weight

The weight of the ConnectCore 91 module is 9.5 g.

Environmental specifications

Operating temperature: -40 to 85 °C.



CAUTION! Your final product may require additional thermal management such as passive (heatsink/spreader) or active (airflow) cooling to achieve the maximum operating temperature without exceeding the processor junction temp limit.
